

# A Story of Units<sup>®</sup>

## Eureka Math<sup>™</sup>

### Grade 3, Module 7

#### Student File\_B

*Contains Sprint and Fluency, Exit Ticket,  
and Assessment Materials*

**Published by the non-profit Great Minds.**

Copyright © 2015 Great Minds. No part of this work may be reproduced, sold, or commercialized, in whole or in part, without written permission from Great Minds. Non-commercial use is licensed pursuant to a Creative Commons Attribution-NonCommercial-ShareAlike 4.0 license; for more information, go to <http://greatminds.net/maps/math/copyright>. “Great Minds” and “Eureka Math” are registered trademarks of Great Minds.

Printed in the U.S.A.

This book may be purchased from the publisher at [eureka-math.org](http://eureka-math.org)

10 9 8 7 6 5 4 3 2 1

# Sprint and Fluency Packet

Multiply.

$3 \times 1 = \underline{\quad}$      $3 \times 2 = \underline{\quad}$      $3 \times 3 = \underline{\quad}$      $3 \times 4 = \underline{\quad}$

$3 \times 5 = \underline{\quad}$      $3 \times 1 = \underline{\quad}$      $3 \times 2 = \underline{\quad}$      $3 \times 1 = \underline{\quad}$

$3 \times 3 = \underline{\quad}$      $3 \times 1 = \underline{\quad}$      $3 \times 4 = \underline{\quad}$      $3 \times 1 = \underline{\quad}$

$3 \times 5 = \underline{\quad}$      $3 \times 1 = \underline{\quad}$      $3 \times 2 = \underline{\quad}$      $3 \times 3 = \underline{\quad}$

$3 \times 2 = \underline{\quad}$      $3 \times 4 = \underline{\quad}$      $3 \times 2 = \underline{\quad}$      $3 \times 5 = \underline{\quad}$

$3 \times 2 = \underline{\quad}$      $3 \times 1 = \underline{\quad}$      $3 \times 2 = \underline{\quad}$      $3 \times 3 = \underline{\quad}$

$3 \times 1 = \underline{\quad}$      $3 \times 3 = \underline{\quad}$      $3 \times 2 = \underline{\quad}$      $3 \times 3 = \underline{\quad}$

$3 \times 4 = \underline{\quad}$      $3 \times 3 = \underline{\quad}$      $3 \times 5 = \underline{\quad}$      $3 \times 3 = \underline{\quad}$

$3 \times 4 = \underline{\quad}$      $3 \times 1 = \underline{\quad}$      $3 \times 4 = \underline{\quad}$      $3 \times 2 = \underline{\quad}$

$3 \times 4 = \underline{\quad}$      $3 \times 3 = \underline{\quad}$      $3 \times 4 = \underline{\quad}$      $3 \times 5 = \underline{\quad}$

$3 \times 4 = \underline{\quad}$      $3 \times 5 = \underline{\quad}$      $3 \times 1 = \underline{\quad}$      $3 \times 5 = \underline{\quad}$

$3 \times 2 = \underline{\quad}$      $3 \times 5 = \underline{\quad}$      $3 \times 3 = \underline{\quad}$      $3 \times 5 = \underline{\quad}$

$3 \times 4 = \underline{\quad}$      $3 \times 2 = \underline{\quad}$      $3 \times 4 = \underline{\quad}$      $3 \times 3 = \underline{\quad}$

$3 \times 5 = \underline{\quad}$      $3 \times 3 = \underline{\quad}$      $3 \times 2 = \underline{\quad}$      $3 \times 4 = \underline{\quad}$

$3 \times 3 = \underline{\quad}$      $3 \times 5 = \underline{\quad}$      $3 \times 2 = \underline{\quad}$      $3 \times 4 = \underline{\quad}$

multiply by 3 (1–5)

Multiply.

$3 \times 1 = \underline{\quad}$      $3 \times 2 = \underline{\quad}$      $3 \times 3 = \underline{\quad}$      $3 \times 4 = \underline{\quad}$

$3 \times 5 = \underline{\quad}$      $3 \times 6 = \underline{\quad}$      $3 \times 7 = \underline{\quad}$      $3 \times 8 = \underline{\quad}$

$3 \times 9 = \underline{\quad}$      $3 \times 10 = \underline{\quad}$      $3 \times 5 = \underline{\quad}$      $3 \times 6 = \underline{\quad}$

$3 \times 5 = \underline{\quad}$      $3 \times 7 = \underline{\quad}$      $3 \times 5 = \underline{\quad}$      $3 \times 8 = \underline{\quad}$

$3 \times 5 = \underline{\quad}$      $3 \times 9 = \underline{\quad}$      $3 \times 5 = \underline{\quad}$      $3 \times 10 = \underline{\quad}$

$3 \times 6 = \underline{\quad}$      $3 \times 5 = \underline{\quad}$      $3 \times 6 = \underline{\quad}$      $3 \times 7 = \underline{\quad}$

$3 \times 6 = \underline{\quad}$      $3 \times 8 = \underline{\quad}$      $3 \times 6 = \underline{\quad}$      $3 \times 9 = \underline{\quad}$

$3 \times 6 = \underline{\quad}$      $3 \times 7 = \underline{\quad}$      $3 \times 6 = \underline{\quad}$      $3 \times 7 = \underline{\quad}$

$3 \times 8 = \underline{\quad}$      $3 \times 7 = \underline{\quad}$      $3 \times 9 = \underline{\quad}$      $3 \times 7 = \underline{\quad}$

$3 \times 8 = \underline{\quad}$      $3 \times 6 = \underline{\quad}$      $3 \times 8 = \underline{\quad}$      $3 \times 7 = \underline{\quad}$

$3 \times 8 = \underline{\quad}$      $3 \times 9 = \underline{\quad}$      $3 \times 9 = \underline{\quad}$      $3 \times 6 = \underline{\quad}$

$3 \times 9 = \underline{\quad}$      $3 \times 7 = \underline{\quad}$      $3 \times 9 = \underline{\quad}$      $3 \times 8 = \underline{\quad}$

$3 \times 9 = \underline{\quad}$      $3 \times 8 = \underline{\quad}$      $3 \times 6 = \underline{\quad}$      $3 \times 9 = \underline{\quad}$

$3 \times 7 = \underline{\quad}$      $3 \times 9 = \underline{\quad}$      $3 \times 6 = \underline{\quad}$      $3 \times 8 = \underline{\quad}$

$3 \times 9 = \underline{\quad}$      $3 \times 7 = \underline{\quad}$      $3 \times 6 = \underline{\quad}$      $3 \times 8 = \underline{\quad}$

multiply by 3 (6–10)

Multiply.

$4 \times 1 = \underline{\quad}$      $4 \times 2 = \underline{\quad}$      $4 \times 3 = \underline{\quad}$      $4 \times 4 = \underline{\quad}$

$4 \times 5 = \underline{\quad}$      $4 \times 1 = \underline{\quad}$      $4 \times 2 = \underline{\quad}$      $4 \times 1 = \underline{\quad}$

$4 \times 3 = \underline{\quad}$      $4 \times 1 = \underline{\quad}$      $4 \times 4 = \underline{\quad}$      $4 \times 1 = \underline{\quad}$

$4 \times 5 = \underline{\quad}$      $4 \times 1 = \underline{\quad}$      $4 \times 2 = \underline{\quad}$      $4 \times 3 = \underline{\quad}$

$4 \times 2 = \underline{\quad}$      $4 \times 4 = \underline{\quad}$      $4 \times 2 = \underline{\quad}$      $4 \times 5 = \underline{\quad}$

$4 \times 2 = \underline{\quad}$      $4 \times 1 = \underline{\quad}$      $4 \times 2 = \underline{\quad}$      $4 \times 3 = \underline{\quad}$

$4 \times 1 = \underline{\quad}$      $4 \times 3 = \underline{\quad}$      $4 \times 2 = \underline{\quad}$      $4 \times 3 = \underline{\quad}$

$4 \times 4 = \underline{\quad}$      $4 \times 3 = \underline{\quad}$      $4 \times 5 = \underline{\quad}$      $4 \times 3 = \underline{\quad}$

$4 \times 4 = \underline{\quad}$      $4 \times 1 = \underline{\quad}$      $4 \times 4 = \underline{\quad}$      $4 \times 2 = \underline{\quad}$

$4 \times 4 = \underline{\quad}$      $4 \times 3 = \underline{\quad}$      $4 \times 4 = \underline{\quad}$      $4 \times 5 = \underline{\quad}$

$4 \times 4 = \underline{\quad}$      $4 \times 5 = \underline{\quad}$      $4 \times 1 = \underline{\quad}$      $4 \times 5 = \underline{\quad}$

$4 \times 2 = \underline{\quad}$      $4 \times 5 = \underline{\quad}$      $4 \times 3 = \underline{\quad}$      $4 \times 5 = \underline{\quad}$

$4 \times 4 = \underline{\quad}$      $4 \times 2 = \underline{\quad}$      $4 \times 4 = \underline{\quad}$      $4 \times 3 = \underline{\quad}$

$4 \times 5 = \underline{\quad}$      $4 \times 3 = \underline{\quad}$      $4 \times 2 = \underline{\quad}$      $4 \times 4 = \underline{\quad}$

$4 \times 3 = \underline{\quad}$      $4 \times 5 = \underline{\quad}$      $4 \times 2 = \underline{\quad}$      $4 \times 4 = \underline{\quad}$

multiply by 4 (1–5)

Multiply.

$4 \times 1 = \underline{\quad}$      $4 \times 2 = \underline{\quad}$      $4 \times 3 = \underline{\quad}$      $4 \times 4 = \underline{\quad}$

$4 \times 5 = \underline{\quad}$      $4 \times 6 = \underline{\quad}$      $4 \times 7 = \underline{\quad}$      $4 \times 8 = \underline{\quad}$

$4 \times 9 = \underline{\quad}$      $4 \times 10 = \underline{\quad}$      $4 \times 5 = \underline{\quad}$      $4 \times 6 = \underline{\quad}$

$4 \times 5 = \underline{\quad}$      $4 \times 7 = \underline{\quad}$      $4 \times 5 = \underline{\quad}$      $4 \times 8 = \underline{\quad}$

$4 \times 5 = \underline{\quad}$      $4 \times 9 = \underline{\quad}$      $4 \times 5 = \underline{\quad}$      $4 \times 10 = \underline{\quad}$

$4 \times 6 = \underline{\quad}$      $4 \times 5 = \underline{\quad}$      $4 \times 6 = \underline{\quad}$      $4 \times 7 = \underline{\quad}$

$4 \times 6 = \underline{\quad}$      $4 \times 8 = \underline{\quad}$      $4 \times 6 = \underline{\quad}$      $4 \times 9 = \underline{\quad}$

$4 \times 6 = \underline{\quad}$      $4 \times 7 = \underline{\quad}$      $4 \times 6 = \underline{\quad}$      $4 \times 7 = \underline{\quad}$

$4 \times 8 = \underline{\quad}$      $4 \times 7 = \underline{\quad}$      $4 \times 9 = \underline{\quad}$      $4 \times 7 = \underline{\quad}$

$4 \times 8 = \underline{\quad}$      $4 \times 6 = \underline{\quad}$      $4 \times 8 = \underline{\quad}$      $4 \times 7 = \underline{\quad}$

$4 \times 8 = \underline{\quad}$      $4 \times 9 = \underline{\quad}$      $4 \times 9 = \underline{\quad}$      $4 \times 6 = \underline{\quad}$

$4 \times 9 = \underline{\quad}$      $4 \times 7 = \underline{\quad}$      $4 \times 9 = \underline{\quad}$      $4 \times 8 = \underline{\quad}$

$4 \times 9 = \underline{\quad}$      $4 \times 8 = \underline{\quad}$      $4 \times 6 = \underline{\quad}$      $4 \times 9 = \underline{\quad}$

$4 \times 7 = \underline{\quad}$      $4 \times 9 = \underline{\quad}$      $4 \times 6 = \underline{\quad}$      $4 \times 8 = \underline{\quad}$

$4 \times 9 = \underline{\quad}$      $4 \times 7 = \underline{\quad}$      $4 \times 6 = \underline{\quad}$      $4 \times 8 = \underline{\quad}$

---

multiply by 4 (6–10)

Multiply.

$5 \times 1 = \underline{\quad\quad}$      $5 \times 2 = \underline{\quad\quad}$      $5 \times 3 = \underline{\quad\quad}$      $5 \times 4 = \underline{\quad\quad}$

$5 \times 5 = \underline{\quad\quad}$      $5 \times 1 = \underline{\quad\quad}$      $5 \times 2 = \underline{\quad\quad}$      $5 \times 1 = \underline{\quad\quad}$

$5 \times 3 = \underline{\quad\quad}$      $5 \times 1 = \underline{\quad\quad}$      $5 \times 4 = \underline{\quad\quad}$      $5 \times 1 = \underline{\quad\quad}$

$5 \times 5 = \underline{\quad\quad}$      $5 \times 1 = \underline{\quad\quad}$      $5 \times 2 = \underline{\quad\quad}$      $5 \times 3 = \underline{\quad\quad}$

$5 \times 2 = \underline{\quad\quad}$      $5 \times 4 = \underline{\quad\quad}$      $5 \times 2 = \underline{\quad\quad}$      $5 \times 5 = \underline{\quad\quad}$

$5 \times 2 = \underline{\quad\quad}$      $5 \times 1 = \underline{\quad\quad}$      $5 \times 2 = \underline{\quad\quad}$      $5 \times 3 = \underline{\quad\quad}$

$5 \times 1 = \underline{\quad\quad}$      $5 \times 3 = \underline{\quad\quad}$      $5 \times 2 = \underline{\quad\quad}$      $5 \times 3 = \underline{\quad\quad}$

$5 \times 4 = \underline{\quad\quad}$      $5 \times 3 = \underline{\quad\quad}$      $5 \times 5 = \underline{\quad\quad}$      $5 \times 3 = \underline{\quad\quad}$

$5 \times 4 = \underline{\quad\quad}$      $5 \times 1 = \underline{\quad\quad}$      $5 \times 4 = \underline{\quad\quad}$      $5 \times 2 = \underline{\quad\quad}$

$5 \times 4 = \underline{\quad\quad}$      $5 \times 3 = \underline{\quad\quad}$      $5 \times 4 = \underline{\quad\quad}$      $5 \times 5 = \underline{\quad\quad}$

$5 \times 4 = \underline{\quad\quad}$      $5 \times 5 = \underline{\quad\quad}$      $5 \times 1 = \underline{\quad\quad}$      $5 \times 5 = \underline{\quad\quad}$

$5 \times 2 = \underline{\quad\quad}$      $5 \times 5 = \underline{\quad\quad}$      $5 \times 3 = \underline{\quad\quad}$      $5 \times 5 = \underline{\quad\quad}$

$5 \times 4 = \underline{\quad\quad}$      $5 \times 2 = \underline{\quad\quad}$      $5 \times 4 = \underline{\quad\quad}$      $5 \times 3 = \underline{\quad\quad}$

$5 \times 5 = \underline{\quad\quad}$      $5 \times 3 = \underline{\quad\quad}$      $5 \times 2 = \underline{\quad\quad}$      $5 \times 4 = \underline{\quad\quad}$

$5 \times 3 = \underline{\quad\quad}$      $5 \times 5 = \underline{\quad\quad}$      $5 \times 2 = \underline{\quad\quad}$      $5 \times 4 = \underline{\quad\quad}$

multiply by 5 (1–5)

Multiply.

$5 \times 1 = \underline{\quad}$      $5 \times 2 = \underline{\quad}$      $5 \times 3 = \underline{\quad}$      $5 \times 4 = \underline{\quad}$

$5 \times 5 = \underline{\quad}$      $5 \times 6 = \underline{\quad}$      $5 \times 7 = \underline{\quad}$      $5 \times 8 = \underline{\quad}$

$5 \times 9 = \underline{\quad}$      $5 \times 10 = \underline{\quad}$      $5 \times 5 = \underline{\quad}$      $5 \times 6 = \underline{\quad}$

$5 \times 5 = \underline{\quad}$      $5 \times 7 = \underline{\quad}$      $5 \times 5 = \underline{\quad}$      $5 \times 8 = \underline{\quad}$

$5 \times 5 = \underline{\quad}$      $5 \times 9 = \underline{\quad}$      $5 \times 5 = \underline{\quad}$      $5 \times 10 = \underline{\quad}$

$5 \times 6 = \underline{\quad}$      $5 \times 5 = \underline{\quad}$      $5 \times 6 = \underline{\quad}$      $5 \times 7 = \underline{\quad}$

$5 \times 6 = \underline{\quad}$      $5 \times 8 = \underline{\quad}$      $5 \times 6 = \underline{\quad}$      $5 \times 9 = \underline{\quad}$

$5 \times 6 = \underline{\quad}$      $5 \times 7 = \underline{\quad}$      $5 \times 6 = \underline{\quad}$      $5 \times 7 = \underline{\quad}$

$5 \times 8 = \underline{\quad}$      $5 \times 7 = \underline{\quad}$      $5 \times 9 = \underline{\quad}$      $5 \times 7 = \underline{\quad}$

$5 \times 8 = \underline{\quad}$      $5 \times 6 = \underline{\quad}$      $5 \times 8 = \underline{\quad}$      $5 \times 7 = \underline{\quad}$

$5 \times 8 = \underline{\quad}$      $5 \times 9 = \underline{\quad}$      $5 \times 9 = \underline{\quad}$      $5 \times 6 = \underline{\quad}$

$5 \times 9 = \underline{\quad}$      $5 \times 7 = \underline{\quad}$      $5 \times 9 = \underline{\quad}$      $5 \times 8 = \underline{\quad}$

$5 \times 9 = \underline{\quad}$      $5 \times 8 = \underline{\quad}$      $5 \times 6 = \underline{\quad}$      $5 \times 9 = \underline{\quad}$

$5 \times 7 = \underline{\quad}$      $5 \times 9 = \underline{\quad}$      $5 \times 6 = \underline{\quad}$      $5 \times 8 = \underline{\quad}$

$5 \times 9 = \underline{\quad}$      $5 \times 7 = \underline{\quad}$      $5 \times 6 = \underline{\quad}$      $5 \times 8 = \underline{\quad}$

multiply by 5 (6–10)



Multiply.

$6 \times 1 = \underline{\quad\quad}$      $6 \times 2 = \underline{\quad\quad}$      $6 \times 3 = \underline{\quad\quad}$      $6 \times 4 = \underline{\quad\quad}$

$6 \times 5 = \underline{\quad\quad}$      $6 \times 1 = \underline{\quad\quad}$      $6 \times 2 = \underline{\quad\quad}$      $6 \times 1 = \underline{\quad\quad}$

$6 \times 3 = \underline{\quad\quad}$      $6 \times 1 = \underline{\quad\quad}$      $6 \times 4 = \underline{\quad\quad}$      $6 \times 1 = \underline{\quad\quad}$

$6 \times 5 = \underline{\quad\quad}$      $6 \times 1 = \underline{\quad\quad}$      $6 \times 2 = \underline{\quad\quad}$      $6 \times 3 = \underline{\quad\quad}$

$6 \times 2 = \underline{\quad\quad}$      $6 \times 4 = \underline{\quad\quad}$      $6 \times 2 = \underline{\quad\quad}$      $6 \times 5 = \underline{\quad\quad}$

$6 \times 2 = \underline{\quad\quad}$      $6 \times 1 = \underline{\quad\quad}$      $6 \times 2 = \underline{\quad\quad}$      $6 \times 3 = \underline{\quad\quad}$

$6 \times 1 = \underline{\quad\quad}$      $6 \times 3 = \underline{\quad\quad}$      $6 \times 2 = \underline{\quad\quad}$      $6 \times 3 = \underline{\quad\quad}$

$6 \times 4 = \underline{\quad\quad}$      $6 \times 3 = \underline{\quad\quad}$      $6 \times 5 = \underline{\quad\quad}$      $6 \times 3 = \underline{\quad\quad}$

$6 \times 4 = \underline{\quad\quad}$      $6 \times 1 = \underline{\quad\quad}$      $6 \times 4 = \underline{\quad\quad}$      $6 \times 2 = \underline{\quad\quad}$

$6 \times 4 = \underline{\quad\quad}$      $6 \times 3 = \underline{\quad\quad}$      $6 \times 4 = \underline{\quad\quad}$      $6 \times 5 = \underline{\quad\quad}$

$6 \times 4 = \underline{\quad\quad}$      $6 \times 5 = \underline{\quad\quad}$      $6 \times 1 = \underline{\quad\quad}$      $6 \times 5 = \underline{\quad\quad}$

$6 \times 2 = \underline{\quad\quad}$      $6 \times 5 = \underline{\quad\quad}$      $6 \times 3 = \underline{\quad\quad}$      $6 \times 5 = \underline{\quad\quad}$

$6 \times 4 = \underline{\quad\quad}$      $6 \times 2 = \underline{\quad\quad}$      $6 \times 4 = \underline{\quad\quad}$      $6 \times 3 = \underline{\quad\quad}$

$6 \times 5 = \underline{\quad\quad}$      $6 \times 3 = \underline{\quad\quad}$      $6 \times 2 = \underline{\quad\quad}$      $6 \times 4 = \underline{\quad\quad}$

$6 \times 3 = \underline{\quad\quad}$      $6 \times 5 = \underline{\quad\quad}$      $6 \times 2 = \underline{\quad\quad}$      $6 \times 4 = \underline{\quad\quad}$

multiply by 6 (1–5)

Multiply.

$6 \times 1 = \underline{\quad}$      $6 \times 2 = \underline{\quad}$      $6 \times 3 = \underline{\quad}$      $6 \times 4 = \underline{\quad}$

$6 \times 5 = \underline{\quad}$      $6 \times 6 = \underline{\quad}$      $6 \times 7 = \underline{\quad}$      $6 \times 8 = \underline{\quad}$

$6 \times 9 = \underline{\quad}$      $6 \times 10 = \underline{\quad}$      $6 \times 5 = \underline{\quad}$      $6 \times 6 = \underline{\quad}$

$6 \times 5 = \underline{\quad}$      $6 \times 7 = \underline{\quad}$      $6 \times 5 = \underline{\quad}$      $6 \times 8 = \underline{\quad}$

$6 \times 5 = \underline{\quad}$      $6 \times 9 = \underline{\quad}$      $6 \times 5 = \underline{\quad}$      $6 \times 10 = \underline{\quad}$

$6 \times 6 = \underline{\quad}$      $6 \times 5 = \underline{\quad}$      $6 \times 6 = \underline{\quad}$      $6 \times 7 = \underline{\quad}$

$6 \times 6 = \underline{\quad}$      $6 \times 8 = \underline{\quad}$      $6 \times 6 = \underline{\quad}$      $6 \times 9 = \underline{\quad}$

$6 \times 6 = \underline{\quad}$      $6 \times 7 = \underline{\quad}$      $6 \times 6 = \underline{\quad}$      $6 \times 7 = \underline{\quad}$

$6 \times 8 = \underline{\quad}$      $6 \times 7 = \underline{\quad}$      $6 \times 9 = \underline{\quad}$      $6 \times 7 = \underline{\quad}$

$6 \times 8 = \underline{\quad}$      $6 \times 6 = \underline{\quad}$      $6 \times 8 = \underline{\quad}$      $6 \times 7 = \underline{\quad}$

$6 \times 8 = \underline{\quad}$      $6 \times 9 = \underline{\quad}$      $6 \times 9 = \underline{\quad}$      $6 \times 6 = \underline{\quad}$

$6 \times 9 = \underline{\quad}$      $6 \times 7 = \underline{\quad}$      $6 \times 9 = \underline{\quad}$      $6 \times 8 = \underline{\quad}$

$6 \times 9 = \underline{\quad}$      $6 \times 8 = \underline{\quad}$      $6 \times 6 = \underline{\quad}$      $6 \times 9 = \underline{\quad}$

$6 \times 7 = \underline{\quad}$      $6 \times 9 = \underline{\quad}$      $6 \times 6 = \underline{\quad}$      $6 \times 8 = \underline{\quad}$

$6 \times 9 = \underline{\quad}$      $6 \times 7 = \underline{\quad}$      $6 \times 6 = \underline{\quad}$      $6 \times 8 = \underline{\quad}$

multiply by 6 (6–10)

Multiply

$7 \times 1 = \underline{\quad\quad}$      $7 \times 2 = \underline{\quad\quad}$      $7 \times 3 = \underline{\quad\quad}$      $7 \times 4 = \underline{\quad\quad}$

$7 \times 5 = \underline{\quad\quad}$      $7 \times 1 = \underline{\quad\quad}$      $7 \times 2 = \underline{\quad\quad}$      $7 \times 1 = \underline{\quad\quad}$

$7 \times 3 = \underline{\quad\quad}$      $7 \times 1 = \underline{\quad\quad}$      $7 \times 4 = \underline{\quad\quad}$      $7 \times 1 = \underline{\quad\quad}$

$7 \times 5 = \underline{\quad\quad}$      $7 \times 1 = \underline{\quad\quad}$      $7 \times 2 = \underline{\quad\quad}$      $7 \times 3 = \underline{\quad\quad}$

$7 \times 2 = \underline{\quad\quad}$      $7 \times 4 = \underline{\quad\quad}$      $7 \times 2 = \underline{\quad\quad}$      $7 \times 5 = \underline{\quad\quad}$

$7 \times 2 = \underline{\quad\quad}$      $7 \times 1 = \underline{\quad\quad}$      $7 \times 2 = \underline{\quad\quad}$      $7 \times 3 = \underline{\quad\quad}$

$7 \times 1 = \underline{\quad\quad}$      $7 \times 3 = \underline{\quad\quad}$      $7 \times 2 = \underline{\quad\quad}$      $7 \times 3 = \underline{\quad\quad}$

$7 \times 4 = \underline{\quad\quad}$      $7 \times 3 = \underline{\quad\quad}$      $7 \times 5 = \underline{\quad\quad}$      $7 \times 3 = \underline{\quad\quad}$

$7 \times 4 = \underline{\quad\quad}$      $7 \times 1 = \underline{\quad\quad}$      $7 \times 4 = \underline{\quad\quad}$      $7 \times 2 = \underline{\quad\quad}$

$7 \times 4 = \underline{\quad\quad}$      $7 \times 3 = \underline{\quad\quad}$      $7 \times 4 = \underline{\quad\quad}$      $7 \times 5 = \underline{\quad\quad}$

$7 \times 4 = \underline{\quad\quad}$      $7 \times 5 = \underline{\quad\quad}$      $7 \times 1 = \underline{\quad\quad}$      $7 \times 5 = \underline{\quad\quad}$

$7 \times 2 = \underline{\quad\quad}$      $7 \times 5 = \underline{\quad\quad}$      $7 \times 3 = \underline{\quad\quad}$      $7 \times 5 = \underline{\quad\quad}$

$7 \times 4 = \underline{\quad\quad}$      $7 \times 2 = \underline{\quad\quad}$      $7 \times 4 = \underline{\quad\quad}$      $7 \times 3 = \underline{\quad\quad}$

$7 \times 5 = \underline{\quad\quad}$      $7 \times 3 = \underline{\quad\quad}$      $7 \times 2 = \underline{\quad\quad}$      $7 \times 4 = \underline{\quad\quad}$

$7 \times 3 = \underline{\quad\quad}$      $7 \times 5 = \underline{\quad\quad}$      $7 \times 2 = \underline{\quad\quad}$      $7 \times 4 = \underline{\quad\quad}$

multiply by 7 (1–5)

Multiply.

$7 \times 1 = \underline{\quad\quad}$      $7 \times 2 = \underline{\quad\quad}$      $7 \times 3 = \underline{\quad\quad}$      $7 \times 4 = \underline{\quad\quad}$

$7 \times 5 = \underline{\quad\quad}$      $7 \times 6 = \underline{\quad\quad}$      $7 \times 7 = \underline{\quad\quad}$      $7 \times 8 = \underline{\quad\quad}$

$7 \times 9 = \underline{\quad\quad}$      $7 \times 10 = \underline{\quad\quad}$      $7 \times 5 = \underline{\quad\quad}$      $7 \times 6 = \underline{\quad\quad}$

$7 \times 5 = \underline{\quad\quad}$      $7 \times 7 = \underline{\quad\quad}$      $7 \times 5 = \underline{\quad\quad}$      $7 \times 8 = \underline{\quad\quad}$

$7 \times 5 = \underline{\quad\quad}$      $7 \times 9 = \underline{\quad\quad}$      $7 \times 5 = \underline{\quad\quad}$      $7 \times 10 = \underline{\quad\quad}$

$7 \times 6 = \underline{\quad\quad}$      $7 \times 5 = \underline{\quad\quad}$      $7 \times 6 = \underline{\quad\quad}$      $7 \times 7 = \underline{\quad\quad}$

$7 \times 6 = \underline{\quad\quad}$      $7 \times 8 = \underline{\quad\quad}$      $7 \times 6 = \underline{\quad\quad}$      $7 \times 9 = \underline{\quad\quad}$

$7 \times 6 = \underline{\quad\quad}$      $7 \times 7 = \underline{\quad\quad}$      $7 \times 6 = \underline{\quad\quad}$      $7 \times 7 = \underline{\quad\quad}$

$7 \times 8 = \underline{\quad\quad}$      $7 \times 7 = \underline{\quad\quad}$      $7 \times 9 = \underline{\quad\quad}$      $7 \times 7 = \underline{\quad\quad}$

$7 \times 8 = \underline{\quad\quad}$      $7 \times 6 = \underline{\quad\quad}$      $7 \times 8 = \underline{\quad\quad}$      $7 \times 7 = \underline{\quad\quad}$

$7 \times 8 = \underline{\quad\quad}$      $7 \times 9 = \underline{\quad\quad}$      $7 \times 9 = \underline{\quad\quad}$      $7 \times 6 = \underline{\quad\quad}$

$7 \times 9 = \underline{\quad\quad}$      $7 \times 7 = \underline{\quad\quad}$      $7 \times 9 = \underline{\quad\quad}$      $7 \times 8 = \underline{\quad\quad}$

$7 \times 9 = \underline{\quad\quad}$      $7 \times 8 = \underline{\quad\quad}$      $7 \times 6 = \underline{\quad\quad}$      $7 \times 9 = \underline{\quad\quad}$

$7 \times 7 = \underline{\quad\quad}$      $7 \times 9 = \underline{\quad\quad}$      $7 \times 6 = \underline{\quad\quad}$      $7 \times 8 = \underline{\quad\quad}$

$7 \times 9 = \underline{\quad\quad}$      $7 \times 7 = \underline{\quad\quad}$      $7 \times 6 = \underline{\quad\quad}$      $7 \times 8 = \underline{\quad\quad}$

multiply by 7 (6–10)

Multiply.

$8 \times 1 = \underline{\quad}$      $8 \times 2 = \underline{\quad}$      $8 \times 3 = \underline{\quad}$      $8 \times 4 = \underline{\quad}$

$8 \times 5 = \underline{\quad}$      $8 \times 1 = \underline{\quad}$      $8 \times 2 = \underline{\quad}$      $8 \times 1 = \underline{\quad}$

$8 \times 3 = \underline{\quad}$      $8 \times 1 = \underline{\quad}$      $8 \times 4 = \underline{\quad}$      $8 \times 1 = \underline{\quad}$

$8 \times 5 = \underline{\quad}$      $8 \times 1 = \underline{\quad}$      $8 \times 2 = \underline{\quad}$      $8 \times 3 = \underline{\quad}$

$8 \times 2 = \underline{\quad}$      $8 \times 4 = \underline{\quad}$      $8 \times 2 = \underline{\quad}$      $8 \times 5 = \underline{\quad}$

$8 \times 2 = \underline{\quad}$      $8 \times 1 = \underline{\quad}$      $8 \times 2 = \underline{\quad}$      $8 \times 3 = \underline{\quad}$

$8 \times 1 = \underline{\quad}$      $8 \times 3 = \underline{\quad}$      $8 \times 2 = \underline{\quad}$      $8 \times 3 = \underline{\quad}$

$8 \times 4 = \underline{\quad}$      $8 \times 3 = \underline{\quad}$      $8 \times 5 = \underline{\quad}$      $8 \times 3 = \underline{\quad}$

$8 \times 4 = \underline{\quad}$      $8 \times 1 = \underline{\quad}$      $8 \times 4 = \underline{\quad}$      $8 \times 2 = \underline{\quad}$

$8 \times 4 = \underline{\quad}$      $8 \times 3 = \underline{\quad}$      $8 \times 4 = \underline{\quad}$      $8 \times 5 = \underline{\quad}$

$8 \times 4 = \underline{\quad}$      $8 \times 5 = \underline{\quad}$      $8 \times 1 = \underline{\quad}$      $8 \times 5 = \underline{\quad}$

$8 \times 2 = \underline{\quad}$      $8 \times 5 = \underline{\quad}$      $8 \times 3 = \underline{\quad}$      $8 \times 5 = \underline{\quad}$

$8 \times 4 = \underline{\quad}$      $8 \times 2 = \underline{\quad}$      $8 \times 4 = \underline{\quad}$      $8 \times 3 = \underline{\quad}$

$8 \times 5 = \underline{\quad}$      $8 \times 3 = \underline{\quad}$      $8 \times 2 = \underline{\quad}$      $8 \times 4 = \underline{\quad}$

$8 \times 3 = \underline{\quad}$      $8 \times 5 = \underline{\quad}$      $8 \times 2 = \underline{\quad}$      $8 \times 4 = \underline{\quad}$

multiply by 8 (1–5)

Multiply.

$8 \times 1 = \underline{\quad\quad}$      $8 \times 2 = \underline{\quad\quad}$      $8 \times 3 = \underline{\quad\quad}$      $8 \times 4 = \underline{\quad\quad}$

$8 \times 5 = \underline{\quad\quad}$      $8 \times 6 = \underline{\quad\quad}$      $8 \times 7 = \underline{\quad\quad}$      $8 \times 8 = \underline{\quad\quad}$

$8 \times 9 = \underline{\quad\quad}$      $8 \times 10 = \underline{\quad\quad}$      $8 \times 5 = \underline{\quad\quad}$      $8 \times 6 = \underline{\quad\quad}$

$8 \times 5 = \underline{\quad\quad}$      $8 \times 7 = \underline{\quad\quad}$      $8 \times 5 = \underline{\quad\quad}$      $8 \times 8 = \underline{\quad\quad}$

$8 \times 5 = \underline{\quad\quad}$      $8 \times 9 = \underline{\quad\quad}$      $8 \times 5 = \underline{\quad\quad}$      $8 \times 10 = \underline{\quad\quad}$

$8 \times 6 = \underline{\quad\quad}$      $8 \times 5 = \underline{\quad\quad}$      $8 \times 6 = \underline{\quad\quad}$      $8 \times 7 = \underline{\quad\quad}$

$8 \times 6 = \underline{\quad\quad}$      $8 \times 8 = \underline{\quad\quad}$      $8 \times 6 = \underline{\quad\quad}$      $8 \times 9 = \underline{\quad\quad}$

$8 \times 6 = \underline{\quad\quad}$      $8 \times 7 = \underline{\quad\quad}$      $8 \times 6 = \underline{\quad\quad}$      $8 \times 7 = \underline{\quad\quad}$

$8 \times 8 = \underline{\quad\quad}$      $8 \times 7 = \underline{\quad\quad}$      $8 \times 9 = \underline{\quad\quad}$      $8 \times 7 = \underline{\quad\quad}$

$8 \times 8 = \underline{\quad\quad}$      $8 \times 6 = \underline{\quad\quad}$      $8 \times 8 = \underline{\quad\quad}$      $8 \times 7 = \underline{\quad\quad}$

$8 \times 8 = \underline{\quad\quad}$      $8 \times 9 = \underline{\quad\quad}$      $8 \times 9 = \underline{\quad\quad}$      $8 \times 6 = \underline{\quad\quad}$

$8 \times 9 = \underline{\quad\quad}$      $8 \times 7 = \underline{\quad\quad}$      $8 \times 9 = \underline{\quad\quad}$      $8 \times 8 = \underline{\quad\quad}$

$8 \times 9 = \underline{\quad\quad}$      $8 \times 8 = \underline{\quad\quad}$      $8 \times 6 = \underline{\quad\quad}$      $8 \times 9 = \underline{\quad\quad}$

$8 \times 7 = \underline{\quad\quad}$      $8 \times 9 = \underline{\quad\quad}$      $8 \times 6 = \underline{\quad\quad}$      $8 \times 8 = \underline{\quad\quad}$

$8 \times 9 = \underline{\quad\quad}$      $8 \times 7 = \underline{\quad\quad}$      $8 \times 6 = \underline{\quad\quad}$      $8 \times 8 = \underline{\quad\quad}$

multiply by 8 (6–10)

Multiply.

$9 \times 1 = \underline{\quad\quad}$      $9 \times 2 = \underline{\quad\quad}$      $9 \times 3 = \underline{\quad\quad}$      $9 \times 4 = \underline{\quad\quad}$

$9 \times 5 = \underline{\quad\quad}$      $9 \times 1 = \underline{\quad\quad}$      $9 \times 2 = \underline{\quad\quad}$      $9 \times 1 = \underline{\quad\quad}$

$9 \times 3 = \underline{\quad\quad}$      $9 \times 1 = \underline{\quad\quad}$      $9 \times 4 = \underline{\quad\quad}$      $9 \times 1 = \underline{\quad\quad}$

$9 \times 5 = \underline{\quad\quad}$      $9 \times 1 = \underline{\quad\quad}$      $9 \times 2 = \underline{\quad\quad}$      $9 \times 3 = \underline{\quad\quad}$

$9 \times 2 = \underline{\quad\quad}$      $9 \times 4 = \underline{\quad\quad}$      $9 \times 2 = \underline{\quad\quad}$      $9 \times 5 = \underline{\quad\quad}$

$9 \times 2 = \underline{\quad\quad}$      $9 \times 1 = \underline{\quad\quad}$      $9 \times 2 = \underline{\quad\quad}$      $9 \times 3 = \underline{\quad\quad}$

$9 \times 1 = \underline{\quad\quad}$      $9 \times 3 = \underline{\quad\quad}$      $9 \times 2 = \underline{\quad\quad}$      $9 \times 3 = \underline{\quad\quad}$

$9 \times 4 = \underline{\quad\quad}$      $9 \times 3 = \underline{\quad\quad}$      $9 \times 5 = \underline{\quad\quad}$      $9 \times 3 = \underline{\quad\quad}$

$9 \times 4 = \underline{\quad\quad}$      $9 \times 1 = \underline{\quad\quad}$      $9 \times 4 = \underline{\quad\quad}$      $9 \times 2 = \underline{\quad\quad}$

$9 \times 4 = \underline{\quad\quad}$      $9 \times 3 = \underline{\quad\quad}$      $9 \times 4 = \underline{\quad\quad}$      $9 \times 5 = \underline{\quad\quad}$

$9 \times 4 = \underline{\quad\quad}$      $9 \times 5 = \underline{\quad\quad}$      $9 \times 1 = \underline{\quad\quad}$      $9 \times 5 = \underline{\quad\quad}$

$9 \times 2 = \underline{\quad\quad}$      $9 \times 5 = \underline{\quad\quad}$      $9 \times 3 = \underline{\quad\quad}$      $9 \times 5 = \underline{\quad\quad}$

$9 \times 4 = \underline{\quad\quad}$      $9 \times 2 = \underline{\quad\quad}$      $9 \times 4 = \underline{\quad\quad}$      $9 \times 3 = \underline{\quad\quad}$

$9 \times 5 = \underline{\quad\quad}$      $9 \times 3 = \underline{\quad\quad}$      $9 \times 2 = \underline{\quad\quad}$      $9 \times 4 = \underline{\quad\quad}$

$9 \times 3 = \underline{\quad\quad}$      $9 \times 5 = \underline{\quad\quad}$      $9 \times 2 = \underline{\quad\quad}$      $9 \times 4 = \underline{\quad\quad}$

multiply by 9 (1–5)

Multiply.

$9 \times 1 = \underline{\quad}$      $9 \times 2 = \underline{\quad}$      $9 \times 3 = \underline{\quad}$      $9 \times 4 = \underline{\quad}$

$9 \times 5 = \underline{\quad}$      $9 \times 6 = \underline{\quad}$      $9 \times 7 = \underline{\quad}$      $9 \times 8 = \underline{\quad}$

$9 \times 9 = \underline{\quad}$      $9 \times 10 = \underline{\quad}$      $9 \times 5 = \underline{\quad}$      $9 \times 6 = \underline{\quad}$

$9 \times 5 = \underline{\quad}$      $9 \times 7 = \underline{\quad}$      $9 \times 5 = \underline{\quad}$      $9 \times 8 = \underline{\quad}$

$9 \times 5 = \underline{\quad}$      $9 \times 9 = \underline{\quad}$      $9 \times 5 = \underline{\quad}$      $9 \times 10 = \underline{\quad}$

$9 \times 6 = \underline{\quad}$      $9 \times 5 = \underline{\quad}$      $9 \times 6 = \underline{\quad}$      $9 \times 7 = \underline{\quad}$

$9 \times 6 = \underline{\quad}$      $9 \times 8 = \underline{\quad}$      $9 \times 6 = \underline{\quad}$      $9 \times 9 = \underline{\quad}$

$9 \times 6 = \underline{\quad}$      $9 \times 7 = \underline{\quad}$      $9 \times 6 = \underline{\quad}$      $9 \times 7 = \underline{\quad}$

$9 \times 8 = \underline{\quad}$      $9 \times 7 = \underline{\quad}$      $9 \times 9 = \underline{\quad}$      $9 \times 7 = \underline{\quad}$

$9 \times 8 = \underline{\quad}$      $9 \times 6 = \underline{\quad}$      $9 \times 8 = \underline{\quad}$      $9 \times 7 = \underline{\quad}$

$9 \times 8 = \underline{\quad}$      $9 \times 9 = \underline{\quad}$      $9 \times 9 = \underline{\quad}$      $9 \times 6 = \underline{\quad}$

$9 \times 9 = \underline{\quad}$      $9 \times 7 = \underline{\quad}$      $9 \times 9 = \underline{\quad}$      $9 \times 8 = \underline{\quad}$

$9 \times 9 = \underline{\quad}$      $9 \times 8 = \underline{\quad}$      $9 \times 6 = \underline{\quad}$      $9 \times 9 = \underline{\quad}$

$9 \times 7 = \underline{\quad}$      $9 \times 9 = \underline{\quad}$      $9 \times 6 = \underline{\quad}$      $9 \times 8 = \underline{\quad}$

$9 \times 9 = \underline{\quad}$      $9 \times 7 = \underline{\quad}$      $9 \times 6 = \underline{\quad}$      $9 \times 8 = \underline{\quad}$

multiply by 9 (6–10)



## A

Number Correct: \_\_\_\_\_

Multiply or Divide by 2

1.	$2 \times 2 =$	
2.	$3 \times 2 =$	
3.	$4 \times 2 =$	
4.	$5 \times 2 =$	
5.	$1 \times 2 =$	
6.	$4 \div 2 =$	
7.	$6 \div 2 =$	
8.	$10 \div 2 =$	
9.	$2 \div 1 =$	
10.	$8 \div 2 =$	
11.	$6 \times 2 =$	
12.	$7 \times 2 =$	
13.	$8 \times 2 =$	
14.	$9 \times 2 =$	
15.	$10 \times 2 =$	
16.	$16 \div 2 =$	
17.	$14 \div 2 =$	
18.	$18 \div 2 =$	
19.	$12 \div 2 =$	
20.	$20 \div 2 =$	
21.	$\underline{\quad} \times 2 = 10$	
22.	$\underline{\quad} \times 2 = 12$	

23.	$\underline{\quad} \times 2 = 20$	
24.	$\underline{\quad} \times 2 = 4$	
25.	$\underline{\quad} \times 2 = 6$	
26.	$20 \div 2 =$	
27.	$10 \div 2 =$	
28.	$2 \div 1 =$	
29.	$4 \div 2 =$	
30.	$6 \div 2 =$	
31.	$\underline{\quad} \times 2 = 12$	
32.	$\underline{\quad} \times 2 = 14$	
33.	$\underline{\quad} \times 2 = 18$	
34.	$\underline{\quad} \times 2 = 16$	
35.	$14 \div 2 =$	
36.	$18 \div 2 =$	
37.	$12 \div 2 =$	
38.	$16 \div 2 =$	
39.	$11 \times 2 =$	
40.	$22 \div 2 =$	
41.	$12 \times 2 =$	
42.	$24 \div 2 =$	
43.	$14 \times 2 =$	
44.	$28 \div 2 =$	

## B

Number Correct: \_\_\_\_\_

Improvement: \_\_\_\_\_

Multiply or Divide by 2

1.	$1 \times 2 =$	
2.	$2 \times 2 =$	
3.	$3 \times 2 =$	
4.	$4 \times 2 =$	
5.	$5 \times 2 =$	
6.	$6 \div 2 =$	
7.	$4 \div 2 =$	
8.	$8 \div 2 =$	
9.	$2 \div 1 =$	
10.	$10 \div 2 =$	
11.	$10 \times 2 =$	
12.	$6 \times 2 =$	
13.	$7 \times 2 =$	
14.	$8 \times 2 =$	
15.	$9 \times 2 =$	
16.	$14 \div 2 =$	
17.	$12 \div 2 =$	
18.	$16 \div 2 =$	
19.	$20 \div 2 =$	
20.	$18 \div 2 =$	
21.	$\underline{\quad} \times 2 = 12$	
22.	$\underline{\quad} \times 2 = 10$	

23.	$\underline{\quad} \times 2 = 4$	
24.	$\underline{\quad} \times 2 = 20$	
25.	$\underline{\quad} \times 2 = 6$	
26.	$4 \div 2 =$	
27.	$2 \div 1 =$	
28.	$20 \div 2 =$	
29.	$10 \div 2 =$	
30.	$6 \div 2 =$	
31.	$\underline{\quad} \times 2 = 12$	
32.	$\underline{\quad} \times 2 = 16$	
33.	$\underline{\quad} \times 2 = 18$	
34.	$\underline{\quad} \times 2 = 14$	
35.	$16 \div 2 =$	
36.	$18 \div 2 =$	
37.	$12 \div 2 =$	
38.	$14 \div 2 =$	
39.	$11 \times 2 =$	
40.	$22 \div 2 =$	
41.	$12 \times 2 =$	
42.	$24 \div 2 =$	
43.	$13 \times 2 =$	
44.	$26 \div 2 =$	

## A

Number Correct: \_\_\_\_\_

Multiply or Divide by 3

1.	$2 \times 3 =$	
2.	$3 \times 3 =$	
3.	$4 \times 3 =$	
4.	$5 \times 3 =$	
5.	$1 \times 3 =$	
6.	$6 \div 3 =$	
7.	$9 \div 3 =$	
8.	$15 \div 3 =$	
9.	$3 \div 3 =$	
10.	$12 \div 3 =$	
11.	$6 \times 3 =$	
12.	$7 \times 3 =$	
13.	$8 \times 3 =$	
14.	$9 \times 3 =$	
15.	$10 \times 3 =$	
16.	$24 \div 3 =$	
17.	$21 \div 3 =$	
18.	$27 \div 3 =$	
19.	$18 \div 3 =$	
20.	$30 \div 3 =$	
21.	$\underline{\quad} \times 3 = 15$	
22.	$\underline{\quad} \times 3 = 3$	

23.	$\underline{\quad} \times 3 = 30$	
24.	$\underline{\quad} \times 3 = 6$	
25.	$\underline{\quad} \times 3 = 9$	
26.	$30 \div 3 =$	
27.	$15 \div 3 =$	
28.	$3 \div 3 =$	
29.	$6 \div 3 =$	
30.	$9 \div 3 =$	
31.	$\underline{\quad} \times 3 = 18$	
32.	$\underline{\quad} \times 3 = 21$	
33.	$\underline{\quad} \times 3 = 27$	
34.	$\underline{\quad} \times 3 = 24$	
35.	$21 \div 3 =$	
36.	$27 \div 3 =$	
37.	$18 \div 3 =$	
38.	$24 \div 3 =$	
39.	$11 \times 3 =$	
40.	$33 \div 3 =$	
41.	$12 \times 3 =$	
42.	$36 \div 3 =$	
43.	$13 \times 3 =$	
44.	$39 \div 3 =$	

## B

Number Correct: \_\_\_\_\_

Improvement: \_\_\_\_\_

Multiply or Divide by 3

1.	$1 \times 3 =$	
2.	$2 \times 3 =$	
3.	$3 \times 3 =$	
4.	$4 \times 3 =$	
5.	$5 \times 3 =$	
6.	$9 \div 3 =$	
7.	$6 \div 3 =$	
8.	$12 \div 3 =$	
9.	$3 \div 3 =$	
10.	$15 \div 3 =$	
11.	$10 \times 3 =$	
12.	$6 \times 3 =$	
13.	$7 \times 3 =$	
14.	$8 \times 3 =$	
15.	$9 \times 3 =$	
16.	$21 \div 3 =$	
17.	$18 \div 3 =$	
18.	$24 \div 3 =$	
19.	$30 \div 3 =$	
20.	$27 \div 3 =$	
21.	$\underline{\quad} \times 3 = 3$	
22.	$\underline{\quad} \times 3 = 15$	

23.	$\underline{\quad} \times 3 = 6$	
24.	$\underline{\quad} \times 3 = 30$	
25.	$\underline{\quad} \times 3 = 9$	
26.	$6 \div 3 =$	
27.	$3 \div 3 =$	
28.	$30 \div 3 =$	
29.	$15 \div 3 =$	
30.	$9 \div 3 =$	
31.	$\underline{\quad} \times 3 = 18$	
32.	$\underline{\quad} \times 3 = 24$	
33.	$\underline{\quad} \times 3 = 27$	
34.	$\underline{\quad} \times 3 = 21$	
35.	$24 \div 3 =$	
36.	$27 \div 3 =$	
37.	$18 \div 3 =$	
38.	$21 \div 3 =$	
39.	$11 \times 3 =$	
40.	$33 \div 3 =$	
41.	$12 \times 3 =$	
42.	$36 \div 3 =$	
43.	$13 \times 3 =$	
44.	$39 \div 3 =$	

## A

Number Correct: \_\_\_\_\_

Multiply or Divide by 4

1.	$2 \times 4 =$	
2.	$3 \times 4 =$	
3.	$4 \times 4 =$	
4.	$5 \times 4 =$	
5.	$1 \times 4 =$	
6.	$8 \div 4 =$	
7.	$12 \div 4 =$	
8.	$20 \div 4 =$	
9.	$4 \div 4 =$	
10.	$16 \div 4 =$	
11.	$6 \times 4 =$	
12.	$7 \times 4 =$	
13.	$8 \times 4 =$	
14.	$9 \times 4 =$	
15.	$10 \times 4 =$	
16.	$32 \div 4 =$	
17.	$28 \div 4 =$	
18.	$36 \div 4 =$	
19.	$24 \div 4 =$	
20.	$40 \div 4 =$	
21.	$\underline{\quad} \times 4 = 20$	
22.	$\underline{\quad} \times 4 = 4$	

23.	$\underline{\quad} \times 4 = 40$	
24.	$\underline{\quad} \times 4 = 8$	
25.	$\underline{\quad} \times 4 = 12$	
26.	$40 \div 4 =$	
27.	$20 \div 4 =$	
28.	$4 \div 4 =$	
29.	$8 \div 4 =$	
30.	$12 \div 4 =$	
31.	$\underline{\quad} \times 4 = 24$	
32.	$\underline{\quad} \times 4 = 28$	
33.	$\underline{\quad} \times 4 = 36$	
34.	$\underline{\quad} \times 4 = 32$	
35.	$28 \div 4 =$	
36.	$36 \div 4 =$	
37.	$24 \div 4 =$	
38.	$32 \div 4 =$	
39.	$11 \times 4 =$	
40.	$44 \div 4 =$	
41.	$12 \div 4 =$	
42.	$48 \div 4 =$	
43.	$14 \times 4 =$	
44.	$56 \div 4 =$	

## B

Number Correct: \_\_\_\_\_

Improvement: \_\_\_\_\_

Multiply or Divide by 4

1.	$1 \times 4 =$	
2.	$2 \times 4 =$	
3.	$3 \times 4 =$	
4.	$4 \times 4 =$	
5.	$5 \times 4 =$	
6.	$12 \div 4 =$	
7.	$8 \div 4 =$	
8.	$16 \div 4 =$	
9.	$4 \div 4 =$	
10.	$20 \div 4 =$	
11.	$10 \times 4 =$	
12.	$6 \times 4 =$	
13.	$7 \times 4 =$	
14.	$8 \times 4 =$	
15.	$9 \times 4 =$	
16.	$28 \div 4 =$	
17.	$24 \div 4 =$	
18.	$32 \div 4 =$	
19.	$40 \div 4 =$	
20.	$36 \div 4 =$	
21.	$\underline{\quad} \times 4 = 4$	
22.	$\underline{\quad} \times 4 = 20$	

23.	$\underline{\quad} \times 4 = 8$	
24.	$\underline{\quad} \times 4 = 40$	
25.	$\underline{\quad} \times 4 = 12$	
26.	$8 \div 4 =$	
27.	$4 \div 4 =$	
28.	$40 \div 4 =$	
29.	$20 \div 4 =$	
30.	$12 \div 4 =$	
31.	$\underline{\quad} \times 4 = 12$	
32.	$\underline{\quad} \times 4 = 16$	
33.	$\underline{\quad} \times 4 = 36$	
34.	$\underline{\quad} \times 4 = 28$	
35.	$32 \div 4 =$	
36.	$36 \div 4 =$	
37.	$24 \div 4 =$	
38.	$28 \div 4 =$	
39.	$11 \times 4 =$	
40.	$44 \div 4 =$	
41.	$12 \times 4 =$	
42.	$48 \div 4 =$	
43.	$13 \times 4 =$	
44.	$52 \div 4 =$	

## A

Number Correct: \_\_\_\_\_

Multiply or Divide by 5

1.	$2 \times 5 =$	
2.	$3 \times 5 =$	
3.	$4 \times 5 =$	
4.	$5 \times 5 =$	
5.	$1 \times 5 =$	
6.	$10 \div 5 =$	
7.	$15 \div 5 =$	
8.	$25 \div 5 =$	
9.	$5 \div 5 =$	
10.	$20 \div 5 =$	
11.	$6 \times 5 =$	
12.	$7 \times 5 =$	
13.	$8 \times 5 =$	
14.	$9 \times 5 =$	
15.	$10 \times 5 =$	
16.	$40 \div 5 =$	
17.	$35 \div 5 =$	
18.	$45 \div 5 =$	
19.	$30 \div 5 =$	
20.	$50 \div 5 =$	
21.	$\underline{\quad} \times 5 = 25$	
22.	$\underline{\quad} \times 5 = 5$	

23.	$\underline{\quad} \times 5 = 50$	
24.	$\underline{\quad} \times 5 = 10$	
25.	$\underline{\quad} \times 5 = 15$	
26.	$50 \div 5 =$	
27.	$25 \div 5 =$	
28.	$5 \div 5 =$	
29.	$10 \div 5 =$	
30.	$15 \div 5 =$	
31.	$\underline{\quad} \times 5 = 30$	
32.	$\underline{\quad} \times 5 = 35$	
33.	$\underline{\quad} \times 5 = 45$	
34.	$\underline{\quad} \times 5 = 40$	
35.	$35 \div 5 =$	
36.	$45 \div 5 =$	
37.	$30 \div 5 =$	
38.	$40 \div 5 =$	
39.	$11 \times 5 =$	
40.	$55 \div 5 =$	
41.	$15 \div 5 =$	
42.	$60 \div 5 =$	
43.	$12 \times 5 =$	
44.	$70 \div 5 =$	

## B

Number Correct: \_\_\_\_\_

Improvement: \_\_\_\_\_

Multiply or Divide by 5

1.	$1 \times 5 =$	
2.	$2 \times 5 =$	
3.	$3 \times 5 =$	
4.	$4 \times 5 =$	
5.	$5 \times 5 =$	
6.	$15 \div 5 =$	
7.	$10 \div 5 =$	
8.	$20 \div 5 =$	
9.	$5 \div 5 =$	
10.	$25 \div 5 =$	
11.	$10 \times 5 =$	
12.	$6 \times 5 =$	
13.	$7 \times 5 =$	
14.	$8 \times 5 =$	
15.	$9 \times 5 =$	
16.	$35 \div 5 =$	
17.	$30 \div 5 =$	
18.	$40 \div 5 =$	
19.	$50 \div 5 =$	
20.	$45 \div 5 =$	
21.	$\_\_\_ \times 5 = 5$	
22.	$\_\_\_ \times 5 = 25$	

23.	$\_\_\_ \times 5 = 10$	
24.	$\_\_\_ \times 5 = 50$	
25.	$\_\_\_ \times 5 = 15$	
26.	$10 \div 5 =$	
27.	$5 \div 5 =$	
28.	$50 \div 5 =$	
29.	$25 \div 5 =$	
30.	$15 \div 5 =$	
31.	$\_\_\_ \times 5 = 15$	
32.	$\_\_\_ \times 5 = 20$	
33.	$\_\_\_ \times 5 = 45$	
34.	$\_\_\_ \times 5 = 35$	
35.	$40 \div 5 =$	
36.	$45 \div 5 =$	
37.	$30 \div 5 =$	
38.	$35 \div 5 =$	
39.	$11 \times 5 =$	
40.	$55 \div 5 =$	
41.	$12 \times 5 =$	
42.	$60 \div 5 =$	
43.	$13 \times 5 =$	
44.	$65 \div 5 =$	



Multiply.

$6 \times 1 = \underline{\quad\quad}$      $6 \times 2 = \underline{\quad\quad}$      $6 \times 3 = \underline{\quad\quad}$      $6 \times 4 = \underline{\quad\quad}$

$6 \times 5 = \underline{\quad\quad}$      $6 \times 6 = \underline{\quad\quad}$      $6 \times 7 = \underline{\quad\quad}$      $6 \times 8 = \underline{\quad\quad}$

$6 \times 9 = \underline{\quad\quad}$      $6 \times 10 = \underline{\quad\quad}$      $6 \times 5 = \underline{\quad\quad}$      $6 \times 6 = \underline{\quad\quad}$

$6 \times 5 = \underline{\quad\quad}$      $6 \times 7 = \underline{\quad\quad}$      $6 \times 5 = \underline{\quad\quad}$      $6 \times 8 = \underline{\quad\quad}$

$6 \times 5 = \underline{\quad\quad}$      $6 \times 9 = \underline{\quad\quad}$      $6 \times 5 = \underline{\quad\quad}$      $6 \times 10 = \underline{\quad\quad}$

$6 \times 6 = \underline{\quad\quad}$      $6 \times 5 = \underline{\quad\quad}$      $6 \times 6 = \underline{\quad\quad}$      $6 \times 7 = \underline{\quad\quad}$

$6 \times 6 = \underline{\quad\quad}$      $6 \times 8 = \underline{\quad\quad}$      $6 \times 6 = \underline{\quad\quad}$      $6 \times 9 = \underline{\quad\quad}$

$6 \times 6 = \underline{\quad\quad}$      $6 \times 7 = \underline{\quad\quad}$      $6 \times 6 = \underline{\quad\quad}$      $6 \times 7 = \underline{\quad\quad}$

$6 \times 8 = \underline{\quad\quad}$      $6 \times 7 = \underline{\quad\quad}$      $6 \times 9 = \underline{\quad\quad}$      $6 \times 7 = \underline{\quad\quad}$

$6 \times 8 = \underline{\quad\quad}$      $6 \times 6 = \underline{\quad\quad}$      $6 \times 8 = \underline{\quad\quad}$      $6 \times 7 = \underline{\quad\quad}$

$6 \times 8 = \underline{\quad\quad}$      $6 \times 9 = \underline{\quad\quad}$      $6 \times 9 = \underline{\quad\quad}$      $6 \times 6 = \underline{\quad\quad}$

$6 \times 9 = \underline{\quad\quad}$      $6 \times 7 = \underline{\quad\quad}$      $6 \times 9 = \underline{\quad\quad}$      $6 \times 8 = \underline{\quad\quad}$

$6 \times 9 = \underline{\quad\quad}$      $6 \times 8 = \underline{\quad\quad}$      $6 \times 6 = \underline{\quad\quad}$      $6 \times 9 = \underline{\quad\quad}$

$6 \times 7 = \underline{\quad\quad}$      $6 \times 9 = \underline{\quad\quad}$      $6 \times 6 = \underline{\quad\quad}$      $6 \times 8 = \underline{\quad\quad}$

$6 \times 9 = \underline{\quad\quad}$      $6 \times 7 = \underline{\quad\quad}$      $6 \times 6 = \underline{\quad\quad}$      $6 \times 8 = \underline{\quad\quad}$

multiply by 6 (6–10)

## A

Number Correct: \_\_\_\_\_

Multiply or Divide by 6

1.	$2 \times 6 =$	
2.	$3 \times 6 =$	
3.	$4 \times 6 =$	
4.	$5 \times 6 =$	
5.	$1 \times 6 =$	
6.	$12 \div 6 =$	
7.	$18 \div 6 =$	
8.	$30 \div 6 =$	
9.	$6 \div 6 =$	
10.	$24 \div 6 =$	
11.	$6 \times 6 =$	
12.	$7 \times 6 =$	
13.	$8 \times 6 =$	
14.	$9 \times 6 =$	
15.	$10 \times 6 =$	
16.	$48 \div 6 =$	
17.	$42 \div 6 =$	
18.	$54 \div 6 =$	
19.	$36 \div 6 =$	
20.	$60 \div 6 =$	
21.	$\underline{\quad} \times 6 = 30$	
22.	$\underline{\quad} \times 6 = 6$	

23.	$\underline{\quad} \times 6 = 60$	
24.	$\underline{\quad} \times 6 = 12$	
25.	$\underline{\quad} \times 6 = 18$	
26.	$60 \div 6 =$	
27.	$30 \div 6 =$	
28.	$6 \div 6 =$	
29.	$12 \div 6 =$	
30.	$18 \div 6 =$	
31.	$\underline{\quad} \times 6 = 36$	
32.	$\underline{\quad} \times 6 = 42$	
33.	$\underline{\quad} \times 6 = 54$	
34.	$\underline{\quad} \times 6 = 48$	
35.	$42 \div 6 =$	
36.	$54 \div 6 =$	
37.	$36 \div 6 =$	
38.	$48 \div 6 =$	
39.	$11 \times 6 =$	
40.	$66 \div 6 =$	
41.	$12 \times 6 =$	
42.	$72 \div 6 =$	
43.	$14 \times 6 =$	
44.	$84 \div 6 =$	

## B

Number Correct: \_\_\_\_\_

Improvement: \_\_\_\_\_

Multiply or Divide by 6

1.	$1 \times 6 =$	
2.	$2 \times 6 =$	
3.	$3 \times 6 =$	
4.	$4 \times 6 =$	
5.	$5 \times 6 =$	
6.	$18 \div 6 =$	
7.	$12 \div 6 =$	
8.	$24 \div 6 =$	
9.	$6 \div 6 =$	
10.	$30 \div 6 =$	
11.	$10 \times 6 =$	
12.	$6 \times 6 =$	
13.	$7 \times 6 =$	
14.	$8 \times 6 =$	
15.	$9 \times 6 =$	
16.	$42 \div 6 =$	
17.	$36 \div 6 =$	
18.	$48 \div 6 =$	
19.	$60 \div 6 =$	
20.	$54 \div 6 =$	
21.	$\underline{\quad} \times 6 = 6$	
22.	$\underline{\quad} \times 6 = 30$	

23.	$\underline{\quad} \times 6 = 12$	
24.	$\underline{\quad} \times 6 = 60$	
25.	$\underline{\quad} \times 6 = 18$	
26.	$12 \div 6 =$	
27.	$6 \div 6 =$	
28.	$60 \div 6 =$	
29.	$30 \div 6 =$	
30.	$18 \div 6 =$	
31.	$\underline{\quad} \times 6 = 18$	
32.	$\underline{\quad} \times 6 = 24$	
33.	$\underline{\quad} \times 6 = 54$	
34.	$\underline{\quad} \times 6 = 42$	
35.	$48 \div 6 =$	
36.	$54 \div 6 =$	
37.	$36 \div 6 =$	
38.	$42 \div 6 =$	
39.	$11 \times 6 =$	
40.	$66 \div 6 =$	
41.	$12 \times 6 =$	
42.	$72 \div 6 =$	
43.	$13 \times 6 =$	
44.	$78 \div 6 =$	

Multiply.

$7 \times 1 = \underline{\quad\quad\quad}$      $7 \times 2 = \underline{\quad\quad\quad}$      $7 \times 3 = \underline{\quad\quad\quad}$      $7 \times 4 = \underline{\quad\quad\quad}$

$7 \times 5 = \underline{\quad\quad\quad}$      $7 \times 6 = \underline{\quad\quad\quad}$      $7 \times 7 = \underline{\quad\quad\quad}$      $7 \times 8 = \underline{\quad\quad\quad}$

$7 \times 9 = \underline{\quad\quad\quad}$      $7 \times 10 = \underline{\quad\quad\quad}$      $7 \times 5 = \underline{\quad\quad\quad}$      $7 \times 6 = \underline{\quad\quad\quad}$

$7 \times 5 = \underline{\quad\quad\quad}$      $7 \times 7 = \underline{\quad\quad\quad}$      $7 \times 5 = \underline{\quad\quad\quad}$      $7 \times 8 = \underline{\quad\quad\quad}$

$7 \times 5 = \underline{\quad\quad\quad}$      $7 \times 9 = \underline{\quad\quad\quad}$      $7 \times 5 = \underline{\quad\quad\quad}$      $7 \times 10 = \underline{\quad\quad\quad}$

$7 \times 6 = \underline{\quad\quad\quad}$      $7 \times 5 = \underline{\quad\quad\quad}$      $7 \times 6 = \underline{\quad\quad\quad}$      $7 \times 7 = \underline{\quad\quad\quad}$

$7 \times 6 = \underline{\quad\quad\quad}$      $7 \times 8 = \underline{\quad\quad\quad}$      $7 \times 6 = \underline{\quad\quad\quad}$      $7 \times 9 = \underline{\quad\quad\quad}$

$7 \times 6 = \underline{\quad\quad\quad}$      $7 \times 7 = \underline{\quad\quad\quad}$      $7 \times 6 = \underline{\quad\quad\quad}$      $7 \times 7 = \underline{\quad\quad\quad}$

$7 \times 8 = \underline{\quad\quad\quad}$      $7 \times 7 = \underline{\quad\quad\quad}$      $7 \times 9 = \underline{\quad\quad\quad}$      $7 \times 7 = \underline{\quad\quad\quad}$

$7 \times 8 = \underline{\quad\quad\quad}$      $7 \times 6 = \underline{\quad\quad\quad}$      $7 \times 8 = \underline{\quad\quad\quad}$      $7 \times 7 = \underline{\quad\quad\quad}$

$7 \times 8 = \underline{\quad\quad\quad}$      $7 \times 9 = \underline{\quad\quad\quad}$      $7 \times 9 = \underline{\quad\quad\quad}$      $7 \times 6 = \underline{\quad\quad\quad}$

$7 \times 9 = \underline{\quad\quad\quad}$      $7 \times 7 = \underline{\quad\quad\quad}$      $7 \times 9 = \underline{\quad\quad\quad}$      $7 \times 8 = \underline{\quad\quad\quad}$

$7 \times 9 = \underline{\quad\quad\quad}$      $7 \times 8 = \underline{\quad\quad\quad}$      $7 \times 6 = \underline{\quad\quad\quad}$      $7 \times 9 = \underline{\quad\quad\quad}$

$7 \times 7 = \underline{\quad\quad\quad}$      $7 \times 9 = \underline{\quad\quad\quad}$      $7 \times 6 = \underline{\quad\quad\quad}$      $7 \times 8 = \underline{\quad\quad\quad}$

$7 \times 9 = \underline{\quad\quad\quad}$      $7 \times 7 = \underline{\quad\quad\quad}$      $7 \times 6 = \underline{\quad\quad\quad}$      $7 \times 8 = \underline{\quad\quad\quad}$

multiply by 7 (6–10)

## A

Number Correct: \_\_\_\_\_

Multiply or Divide by 7

1.	$2 \times 7 =$	
2.	$3 \times 7 =$	
3.	$4 \times 7 =$	
4.	$5 \times 7 =$	
5.	$1 \times 7 =$	
6.	$14 \div 7 =$	
7.	$21 \div 7 =$	
8.	$35 \div 7 =$	
9.	$7 \div 7 =$	
10.	$28 \div 7 =$	
11.	$6 \times 7 =$	
12.	$7 \times 7 =$	
13.	$8 \times 7 =$	
14.	$9 \times 7 =$	
15.	$10 \times 7 =$	
16.	$56 \div 7 =$	
17.	$49 \div 7 =$	
18.	$63 \div 7 =$	
19.	$42 \div 7 =$	
20.	$70 \div 7 =$	
21.	$\underline{\quad} \times 7 = 35$	
22.	$\underline{\quad} \times 7 = 7$	

23.	$\underline{\quad} \times 7 = 70$	
24.	$\underline{\quad} \times 7 = 14$	
25.	$\underline{\quad} \times 7 = 21$	
26.	$70 \div 7 =$	
27.	$35 \div 7 =$	
28.	$7 \div 7 =$	
29.	$14 \div 7 =$	
30.	$21 \div 7 =$	
31.	$\underline{\quad} \times 7 = 42$	
32.	$\underline{\quad} \times 7 = 49$	
33.	$\underline{\quad} \times 7 = 63$	
34.	$\underline{\quad} \times 7 = 56$	
35.	$49 \div 7 =$	
36.	$63 \div 7 =$	
37.	$42 \div 7 =$	
38.	$56 \div 7 =$	
39.	$11 \times 7 =$	
40.	$77 \div 7 =$	
41.	$12 \times 7 =$	
42.	$84 \div 7 =$	
43.	$14 \times 7 =$	
44.	$98 \div 7 =$	

## B

Number Correct: \_\_\_\_\_

Improvement: \_\_\_\_\_

Multiply or Divide by 7

1.	$1 \times 7 =$	
2.	$2 \times 7 =$	
3.	$3 \times 7 =$	
4.	$4 \times 7 =$	
5.	$5 \times 7 =$	
6.	$21 \div 7 =$	
7.	$14 \div 7 =$	
8.	$28 \div 7 =$	
9.	$7 \div 7 =$	
10.	$35 \div 7 =$	
11.	$10 \times 7 =$	
12.	$6 \times 7 =$	
13.	$7 \times 7 =$	
14.	$8 \times 7 =$	
15.	$9 \times 7 =$	
16.	$49 \div 7 =$	
17.	$42 \div 7 =$	
18.	$56 \div 7 =$	
19.	$70 \div 7 =$	
20.	$63 \div 7 =$	
21.	$\underline{\quad} \times 7 = 7$	
22.	$\underline{\quad} \times 7 = 35$	

23.	$\underline{\quad} \times 7 = 14$	
24.	$\underline{\quad} \times 7 = 70$	
25.	$\underline{\quad} \times 7 = 21$	
26.	$14 \div 7 =$	
27.	$7 \div 7 =$	
28.	$70 \div 7 =$	
29.	$35 \div 7 =$	
30.	$21 \div 7 =$	
31.	$\underline{\quad} \times 7 = 21$	
32.	$\underline{\quad} \times 7 = 28$	
33.	$\underline{\quad} \times 7 = 63$	
34.	$\underline{\quad} \times 7 = 49$	
35.	$56 \div 7 =$	
36.	$63 \div 7 =$	
37.	$42 \div 7 =$	
38.	$49 \div 7 =$	
39.	$11 \times 7 =$	
40.	$77 \div 7 =$	
41.	$12 \times 7 =$	
42.	$84 \div 7 =$	
43.	$13 \times 7 =$	
44.	$91 \div 7 =$	

Multiply.

$8 \times 1 = \underline{\quad\quad}$      $8 \times 2 = \underline{\quad\quad}$      $8 \times 3 = \underline{\quad\quad}$      $8 \times 4 = \underline{\quad\quad}$

$8 \times 5 = \underline{\quad\quad}$      $8 \times 6 = \underline{\quad\quad}$      $8 \times 7 = \underline{\quad\quad}$      $8 \times 8 = \underline{\quad\quad}$

$8 \times 9 = \underline{\quad\quad}$      $8 \times 10 = \underline{\quad\quad}$      $8 \times 5 = \underline{\quad\quad}$      $8 \times 6 = \underline{\quad\quad}$

$8 \times 5 = \underline{\quad\quad}$      $8 \times 7 = \underline{\quad\quad}$      $8 \times 5 = \underline{\quad\quad}$      $8 \times 8 = \underline{\quad\quad}$

$8 \times 5 = \underline{\quad\quad}$      $8 \times 9 = \underline{\quad\quad}$      $8 \times 5 = \underline{\quad\quad}$      $8 \times 10 = \underline{\quad\quad}$

$8 \times 6 = \underline{\quad\quad}$      $8 \times 5 = \underline{\quad\quad}$      $8 \times 6 = \underline{\quad\quad}$      $8 \times 7 = \underline{\quad\quad}$

$8 \times 6 = \underline{\quad\quad}$      $8 \times 8 = \underline{\quad\quad}$      $8 \times 6 = \underline{\quad\quad}$      $8 \times 9 = \underline{\quad\quad}$

$8 \times 6 = \underline{\quad\quad}$      $8 \times 7 = \underline{\quad\quad}$      $8 \times 6 = \underline{\quad\quad}$      $8 \times 7 = \underline{\quad\quad}$

$8 \times 8 = \underline{\quad\quad}$      $8 \times 7 = \underline{\quad\quad}$      $8 \times 9 = \underline{\quad\quad}$      $8 \times 7 = \underline{\quad\quad}$

$8 \times 8 = \underline{\quad\quad}$      $8 \times 6 = \underline{\quad\quad}$      $8 \times 8 = \underline{\quad\quad}$      $8 \times 7 = \underline{\quad\quad}$

$8 \times 8 = \underline{\quad\quad}$      $8 \times 9 = \underline{\quad\quad}$      $8 \times 9 = \underline{\quad\quad}$      $8 \times 6 = \underline{\quad\quad}$

$8 \times 9 = \underline{\quad\quad}$      $8 \times 7 = \underline{\quad\quad}$      $8 \times 9 = \underline{\quad\quad}$      $8 \times 8 = \underline{\quad\quad}$

$8 \times 9 = \underline{\quad\quad}$      $8 \times 8 = \underline{\quad\quad}$      $8 \times 6 = \underline{\quad\quad}$      $8 \times 9 = \underline{\quad\quad}$

$8 \times 7 = \underline{\quad\quad}$      $8 \times 9 = \underline{\quad\quad}$      $8 \times 6 = \underline{\quad\quad}$      $8 \times 8 = \underline{\quad\quad}$

$8 \times 9 = \underline{\quad\quad}$      $8 \times 7 = \underline{\quad\quad}$      $8 \times 6 = \underline{\quad\quad}$      $8 \times 8 = \underline{\quad\quad}$

multiply by 8 (6–10)

## A

Number Correct: \_\_\_\_\_

Multiply or Divide by 8

1.	$2 \times 8 =$	
2.	$3 \times 8 =$	
3.	$4 \times 8 =$	
4.	$5 \times 8 =$	
5.	$1 \times 8 =$	
6.	$16 \div 8 =$	
7.	$24 \div 8 =$	
8.	$40 \div 8 =$	
9.	$8 \div 8 =$	
10.	$32 \div 8 =$	
11.	$6 \times 8 =$	
12.	$7 \times 8 =$	
13.	$8 \times 8 =$	
14.	$9 \times 8 =$	
15.	$10 \times 8 =$	
16.	$64 \div 8 =$	
17.	$56 \div 8 =$	
18.	$72 \div 8 =$	
19.	$48 \div 8 =$	
20.	$80 \div 8 =$	
21.	$\underline{\quad} \times 8 = 40$	
22.	$\underline{\quad} \times 8 = 8$	

23.	$\underline{\quad} \times 8 = 80$	
24.	$\underline{\quad} \times 8 = 16$	
25.	$\underline{\quad} \times 8 = 24$	
26.	$80 \div 8 =$	
27.	$40 \div 8 =$	
28.	$8 \div 8 =$	
29.	$16 \div 8 =$	
30.	$24 \div 8 =$	
31.	$\underline{\quad} \times 8 = 48$	
32.	$\underline{\quad} \times 8 = 56$	
33.	$\underline{\quad} \times 8 = 72$	
34.	$\underline{\quad} \times 8 = 64$	
35.	$56 \div 8 =$	
36.	$72 \div 8 =$	
37.	$48 \div 8 =$	
38.	$64 \div 8 =$	
39.	$11 \times 8 =$	
40.	$88 \div 8 =$	
41.	$12 \times 8 =$	
42.	$96 \div 8 =$	
43.	$14 \times 8 =$	
44.	$112 \div 8 =$	



## B

Number Correct: \_\_\_\_\_

Improvement: \_\_\_\_\_

Multiply or Divide by 8

1.	$1 \times 8 =$	
2.	$2 \times 8 =$	
3.	$3 \times 8 =$	
4.	$4 \times 8 =$	
5.	$5 \times 8 =$	
6.	$24 \div 8 =$	
7.	$16 \div 8 =$	
8.	$32 \div 8 =$	
9.	$8 \div 8 =$	
10.	$40 \div 8 =$	
11.	$10 \times 8 =$	
12.	$6 \times 8 =$	
13.	$7 \times 8 =$	
14.	$8 \times 8 =$	
15.	$9 \times 8 =$	
16.	$56 \div 8 =$	
17.	$8 \div 8 =$	
18.	$64 \div 8 =$	
19.	$80 \div 8 =$	
20.	$72 \div 8 =$	
21.	$\underline{\quad} \times 8 = 8$	
22.	$\underline{\quad} \times 8 = 40$	

23.	$\underline{\quad} \times 8 = 16$	
24.	$\underline{\quad} \times 8 = 80$	
25.	$\underline{\quad} \times 8 = 24$	
26.	$16 \div 8 =$	
27.	$8 \div 8 =$	
28.	$80 \div 8 =$	
29.	$40 \div 8 =$	
30.	$24 \div 8 =$	
31.	$\underline{\quad} \times 8 = 24$	
32.	$\underline{\quad} \times 8 = 32$	
33.	$\underline{\quad} \times 8 = 72$	
34.	$\underline{\quad} \times 8 = 56$	
35.	$64 \div 8 =$	
36.	$72 \div 8 =$	
37.	$48 \div 8 =$	
38.	$56 \div 8 =$	
39.	$11 \times 8 =$	
40.	$88 \div 8 =$	
41.	$12 \times 8 =$	
42.	$96 \div 8 =$	
43.	$13 \times 8 =$	
44.	$104 \div 8 =$	

Multiply.

$9 \times 1 = \underline{\quad\quad\quad}$      $9 \times 2 = \underline{\quad\quad\quad}$      $9 \times 3 = \underline{\quad\quad\quad}$      $9 \times 4 = \underline{\quad\quad\quad}$

$9 \times 5 = \underline{\quad\quad\quad}$      $9 \times 6 = \underline{\quad\quad\quad}$      $9 \times 7 = \underline{\quad\quad\quad}$      $9 \times 8 = \underline{\quad\quad\quad}$

$9 \times 9 = \underline{\quad\quad\quad}$      $9 \times 10 = \underline{\quad\quad\quad}$      $9 \times 5 = \underline{\quad\quad\quad}$      $9 \times 6 = \underline{\quad\quad\quad}$

$9 \times 5 = \underline{\quad\quad\quad}$      $9 \times 7 = \underline{\quad\quad\quad}$      $9 \times 5 = \underline{\quad\quad\quad}$      $9 \times 8 = \underline{\quad\quad\quad}$

$9 \times 5 = \underline{\quad\quad\quad}$      $9 \times 9 = \underline{\quad\quad\quad}$      $9 \times 5 = \underline{\quad\quad\quad}$      $9 \times 10 = \underline{\quad\quad\quad}$

$9 \times 6 = \underline{\quad\quad\quad}$      $9 \times 5 = \underline{\quad\quad\quad}$      $9 \times 6 = \underline{\quad\quad\quad}$      $9 \times 7 = \underline{\quad\quad\quad}$

$9 \times 6 = \underline{\quad\quad\quad}$      $9 \times 8 = \underline{\quad\quad\quad}$      $9 \times 6 = \underline{\quad\quad\quad}$      $9 \times 9 = \underline{\quad\quad\quad}$

$9 \times 6 = \underline{\quad\quad\quad}$      $9 \times 7 = \underline{\quad\quad\quad}$      $9 \times 6 = \underline{\quad\quad\quad}$      $9 \times 7 = \underline{\quad\quad\quad}$

$9 \times 8 = \underline{\quad\quad\quad}$      $9 \times 7 = \underline{\quad\quad\quad}$      $9 \times 9 = \underline{\quad\quad\quad}$      $9 \times 7 = \underline{\quad\quad\quad}$

$9 \times 8 = \underline{\quad\quad\quad}$      $9 \times 6 = \underline{\quad\quad\quad}$      $9 \times 8 = \underline{\quad\quad\quad}$      $9 \times 7 = \underline{\quad\quad\quad}$

$9 \times 8 = \underline{\quad\quad\quad}$      $9 \times 9 = \underline{\quad\quad\quad}$      $9 \times 9 = \underline{\quad\quad\quad}$      $9 \times 6 = \underline{\quad\quad\quad}$

$9 \times 9 = \underline{\quad\quad\quad}$      $9 \times 7 = \underline{\quad\quad\quad}$      $9 \times 9 = \underline{\quad\quad\quad}$      $9 \times 8 = \underline{\quad\quad\quad}$

$9 \times 9 = \underline{\quad\quad\quad}$      $9 \times 8 = \underline{\quad\quad\quad}$      $9 \times 6 = \underline{\quad\quad\quad}$      $9 \times 9 = \underline{\quad\quad\quad}$

$9 \times 7 = \underline{\quad\quad\quad}$      $9 \times 9 = \underline{\quad\quad\quad}$      $9 \times 6 = \underline{\quad\quad\quad}$      $9 \times 8 = \underline{\quad\quad\quad}$

$9 \times 9 = \underline{\quad\quad\quad}$      $9 \times 7 = \underline{\quad\quad\quad}$      $9 \times 6 = \underline{\quad\quad\quad}$      $9 \times 8 = \underline{\quad\quad\quad}$

multiply by 9 (6–10)

## A

Number Correct: \_\_\_\_\_

Multiply or Divide by 9

1.	$2 \times 9 =$	
2.	$3 \times 9 =$	
3.	$4 \times 9 =$	
4.	$5 \times 9 =$	
5.	$1 \times 9 =$	
6.	$18 \div 9 =$	
7.	$27 \div 9 =$	
8.	$45 \div 9 =$	
9.	$9 \div 9 =$	
10.	$36 \div 9 =$	
11.	$6 \times 9 =$	
12.	$7 \times 9 =$	
13.	$8 \times 9 =$	
14.	$9 \times 9 =$	
15.	$10 \times 9 =$	
16.	$72 \div 9 =$	
17.	$63 \div 9 =$	
18.	$81 \div 9 =$	
19.	$54 \div 9 =$	
20.	$90 \div 9 =$	
21.	$\underline{\quad} \times 9 = 45$	
22.	$\underline{\quad} \times 9 = 9$	

23.	$\underline{\quad} \times 9 = 90$	
24.	$\underline{\quad} \times 9 = 18$	
25.	$\underline{\quad} \times 9 = 27$	
26.	$90 \div 9 =$	
27.	$45 \div 9 =$	
28.	$9 \div 9 =$	
29.	$18 \div 9 =$	
30.	$27 \div 9 =$	
31.	$\underline{\quad} \times 9 = 54$	
32.	$\underline{\quad} \times 9 = 63$	
33.	$\underline{\quad} \times 9 = 81$	
34.	$\underline{\quad} \times 9 = 72$	
35.	$63 \div 9 =$	
36.	$81 \div 9 =$	
37.	$54 \div 9 =$	
38.	$72 \div 9 =$	
39.	$11 \times 9 =$	
40.	$99 \div 9 =$	
41.	$12 \times 9 =$	
42.	$108 \div 9 =$	
43.	$14 \times 9 =$	
44.	$126 \div 9 =$	

## B

Number Correct: \_\_\_\_\_

Improvement: \_\_\_\_\_

Multiply or Divide by 9

1.	$1 \times 9 =$	
2.	$2 \times 9 =$	
3.	$3 \times 9 =$	
4.	$4 \times 9 =$	
5.	$5 \times 9 =$	
6.	$27 \div 9 =$	
7.	$18 \div 9 =$	
8.	$36 \div 9 =$	
9.	$9 \div 9 =$	
10.	$45 \div 9 =$	
11.	$10 \times 9 =$	
12.	$6 \times 9 =$	
13.	$7 \times 9 =$	
14.	$8 \times 9 =$	
15.	$9 \times 9 =$	
16.	$63 \div 9 =$	
17.	$54 \div 9 =$	
18.	$72 \div 9 =$	
19.	$90 \div 9 =$	
20.	$81 \div 9 =$	
21.	$\underline{\quad} \times 9 = 9$	
22.	$\underline{\quad} \times 9 = 45$	

23.	$\underline{\quad} \times 9 = 18$	
24.	$\underline{\quad} \times 9 = 90$	
25.	$\underline{\quad} \times 9 = 27$	
26.	$18 \div 9 =$	
27.	$9 \div 9 =$	
28.	$90 \div 9 =$	
29.	$45 \div 9 =$	
30.	$27 \div 9 =$	
31.	$\underline{\quad} \times 9 = 27$	
32.	$\underline{\quad} \times 9 = 36$	
33.	$\underline{\quad} \times 9 = 81$	
34.	$\underline{\quad} \times 9 = 63$	
35.	$72 \div 9 =$	
36.	$81 \div 9 =$	
37.	$54 \div 9 =$	
38.	$63 \div 9 =$	
39.	$11 \times 9 =$	
40.	$99 \div 9 =$	
41.	$12 \times 9 =$	
42.	$108 \div 9 =$	
43.	$13 \times 9 =$	
44.	$117 \div 9 =$	

## A

Number Correct: \_\_\_\_\_

## Mixed Multiplication

1.	$2 \times 1 =$	
2.	$2 \times 2 =$	
3.	$2 \times 3 =$	
4.	$4 \times 1 =$	
5.	$4 \times 2 =$	
6.	$4 \times 3 =$	
7.	$1 \times 6 =$	
8.	$2 \times 6 =$	
9.	$1 \times 8 =$	
10.	$2 \times 8 =$	
11.	$3 \times 1 =$	
12.	$3 \times 2 =$	
13.	$3 \times 3 =$	
14.	$5 \times 1 =$	
15.	$5 \times 2 =$	
16.	$5 \times 3 =$	
17.	$1 \times 7 =$	
18.	$2 \times 7 =$	
19.	$1 \times 9 =$	
20.	$2 \times 9 =$	
21.	$2 \times 5 =$	
22.	$2 \times 6 =$	

23.	$2 \times 7 =$	
24.	$5 \times 5 =$	
25.	$5 \times 6 =$	
26.	$5 \times 7 =$	
27.	$4 \times 5 =$	
28.	$4 \times 6 =$	
29.	$4 \times 7 =$	
30.	$3 \times 5 =$	
31.	$3 \times 6 =$	
32.	$3 \times 7 =$	
33.	$2 \times 7 =$	
34.	$2 \times 8 =$	
35.	$2 \times 9 =$	
36.	$5 \times 7 =$	
37.	$5 \times 8 =$	
38.	$5 \times 9 =$	
39.	$4 \times 7 =$	
40.	$4 \times 8 =$	
41.	$4 \times 9 =$	
42.	$3 \times 7 =$	
43.	$3 \times 8 =$	
44.	$3 \times 9 =$	

## B

Number Correct: \_\_\_\_\_

Improvement: \_\_\_\_\_

## Mixed Multiplication

1.	$5 \times 1 =$	
2.	$5 \times 2 =$	
3.	$5 \times 3 =$	
4.	$3 \times 1 =$	
5.	$3 \times 2 =$	
6.	$3 \times 3 =$	
7.	$1 \times 7 =$	
8.	$2 \times 7 =$	
9.	$1 \times 9 =$	
10.	$2 \times 9 =$	
11.	$2 \times 1 =$	
12.	$2 \times 2 =$	
13.	$2 \times 3 =$	
14.	$4 \times 1 =$	
15.	$4 \times 2 =$	
16.	$4 \times 3 =$	
17.	$1 \times 6 =$	
18.	$2 \times 6 =$	
19.	$1 \times 8 =$	
20.	$2 \times 8 =$	
21.	$5 \times 5 =$	
22.	$5 \times 6 =$	

23.	$5 \times 7 =$	
24.	$2 \times 5 =$	
25.	$2 \times 6 =$	
26.	$2 \times 7 =$	
27.	$3 \times 5 =$	
28.	$3 \times 6 =$	
29.	$3 \times 7 =$	
30.	$4 \times 5 =$	
31.	$4 \times 6 =$	
32.	$4 \times 7 =$	
33.	$5 \times 7 =$	
34.	$5 \times 8 =$	
35.	$5 \times 9 =$	
36.	$2 \times 7 =$	
37.	$2 \times 8 =$	
38.	$2 \times 9 =$	
39.	$3 \times 7 =$	
40.	$3 \times 8 =$	
41.	$3 \times 9 =$	
42.	$4 \times 7 =$	
43.	$4 \times 8 =$	
44.	$4 \times 9 =$	

## A

Number Correct: \_\_\_\_\_

## Mixed Division

1.	$4 \div 2 =$	
2.	$6 \div 2 =$	
3.	$10 \div 2 =$	
4.	$20 \div 2 =$	
5.	$10 \div 5 =$	
6.	$15 \div 5 =$	
7.	$25 \div 5 =$	
8.	$20 \div 5 =$	
9.	$8 \div 4 =$	
10.	$12 \div 4 =$	
11.	$20 \div 4 =$	
12.	$16 \div 4 =$	
13.	$6 \div 3 =$	
14.	$9 \div 3 =$	
15.	$15 \div 3 =$	
16.	$12 \div 3 =$	
17.	$60 \div 6 =$	
18.	$12 \div 6 =$	
19.	$18 \div 6 =$	
20.	$35 \div 7 =$	
21.	$14 \div 7 =$	
22.	$21 \div 7 =$	

23.	$16 \div 8 =$	
24.	$40 \div 8 =$	
25.	$32 \div 8 =$	
26.	$56 \div 8 =$	
27.	$18 \div 9 =$	
28.	$45 \div 9 =$	
29.	$36 \div 9 =$	
30.	$63 \div 9 =$	
31.	$64 \div 8 =$	
32.	$48 \div 8 =$	
33.	$81 \div 9 =$	
34.	$54 \div 9 =$	
35.	$24 \div 6 =$	
36.	$16 \div 2 =$	
37.	$28 \div 7 =$	
38.	$27 \div 3 =$	
39.	$24 \div 8 =$	
40.	$32 \div 4 =$	
41.	$27 \div 9 =$	
42.	$72 \div 9 =$	
43.	$56 \div 7 =$	
44.	$72 \div 8 =$	

## B

Number Correct: \_\_\_\_\_

Improvement: \_\_\_\_\_

## Mixed Division

1.	$10 \div 5 =$	
2.	$15 \div 5 =$	
3.	$25 \div 5 =$	
4.	$50 \div 5 =$	
5.	$4 \div 2 =$	
6.	$6 \div 2 =$	
7.	$10 \div 2 =$	
8.	$8 \div 2 =$	
9.	$6 \div 3 =$	
10.	$9 \div 3 =$	
11.	$15 \div 3 =$	
12.	$12 \div 3 =$	
13.	$8 \div 4 =$	
14.	$12 \div 4 =$	
15.	$20 \div 4 =$	
16.	$16 \div 4 =$	
17.	$70 \div 7 =$	
18.	$14 \div 7 =$	
19.	$21 \div 7 =$	
20.	$30 \div 6 =$	
21.	$12 \div 6 =$	
22.	$18 \div 6 =$	

23.	$18 \div 9 =$	
24.	$45 \div 9 =$	
25.	$27 \div 9 =$	
26.	$63 \div 9 =$	
27.	$16 \div 8 =$	
28.	$40 \div 8 =$	
29.	$24 \div 8 =$	
30.	$56 \div 8 =$	
31.	$81 \div 9 =$	
32.	$54 \div 9 =$	
33.	$64 \div 8 =$	
34.	$48 \div 8 =$	
35.	$30 \div 6 =$	
36.	$18 \div 2 =$	
37.	$35 \div 7 =$	
38.	$24 \div 3 =$	
39.	$32 \div 8 =$	
40.	$36 \div 4 =$	
41.	$45 \div 9 =$	
42.	$72 \div 8 =$	
43.	$49 \div 7 =$	
44.	$72 \div 9 =$	



## A

Number Correct: \_\_\_\_\_

## Multiply and Divide

1.	$3 \times 2 =$	
2.	$6 \div 2 =$	
3.	$5 \times 3 =$	
4.	$15 \div 5 =$	
5.	$4 \times 2 =$	
6.	$8 \div 4 =$	
7.	$3 \times 3 =$	
8.	$9 \div 3 =$	
9.	$4 \times 3 =$	
10.	$12 \div 4 =$	
11.	$5 \times 5 =$	
12.	$25 \div 5 =$	
13.	$6 \times 2 =$	
14.	$21 \div 7 =$	
15.	$7 \times 4 =$	
16.	$16 \div 8 =$	
17.	$18 \div 3 =$	
18.	$18 \div 9 =$	
19.	$8 \times 3 =$	
20.	$36 \div 9 =$	
21.	$14 \div 7 =$	
22.	$6 \times 4 =$	

23.	$2 \times 7 =$	
24.	$3 \times 8 =$	
25.	$4 \times 9 =$	
26.	$5 \times 7 =$	
27.	$36 \div 6 =$	
28.	$42 \div 7 =$	
29.	$64 \div 8 =$	
30.	$45 \div 9 =$	
31.	$2 \times 8 =$	
32.	$3 \times 9 =$	
33.	$32 \div 4 =$	
34.	$45 \div 5 =$	
35.	$6 \times 7 =$	
36.	$7 \times 7 =$	
37.	$56 \div 8 =$	
38.	$63 \div 9 =$	
39.	$6 \times 6 =$	
40.	$8 \times 8 =$	
41.	$81 \div 9 =$	
42.	$49 \div 7 =$	
43.	$54 \div 6 =$	
44.	$56 \div 7 =$	

## B

Number Correct: \_\_\_\_\_

Improvement: \_\_\_\_\_

## Multiply and Divide

1.	$5 \times 2 =$	
2.	$10 \div 2 =$	
3.	$2 \times 3 =$	
4.	$6 \div 3 =$	
5.	$3 \times 2 =$	
6.	$6 \div 2 =$	
7.	$4 \times 4 =$	
8.	$16 \div 4 =$	
9.	$3 \times 4 =$	
10.	$12 \div 3 =$	
11.	$3 \times 3 =$	
12.	$9 \div 3 =$	
13.	$7 \times 2 =$	
14.	$18 \div 6 =$	
15.	$6 \times 4 =$	
16.	$18 \div 9 =$	
17.	$21 \div 3 =$	
18.	$16 \div 8 =$	
19.	$9 \times 3 =$	
20.	$32 \div 8 =$	
21.	$12 \div 6 =$	
22.	$7 \times 4 =$	

23.	$2 \times 7 =$	
24.	$3 \times 8 =$	
25.	$4 \times 9 =$	
26.	$5 \times 7 =$	
27.	$36 \div 6 =$	
28.	$42 \div 7 =$	
29.	$64 \div 8 =$	
30.	$45 \div 9 =$	
31.	$2 \times 8 =$	
32.	$3 \times 9 =$	
33.	$32 \div 4 =$	
34.	$45 \div 5 =$	
35.	$6 \times 7 =$	
36.	$7 \times 7 =$	
37.	$56 \div 8 =$	
38.	$63 \div 9 =$	
39.	$6 \times 6 =$	
40.	$8 \times 8 =$	
41.	$81 \div 9 =$	
42.	$49 \div 7 =$	
43.	$54 \div 6 =$	
44.	$56 \div 7 =$	

# Exit Ticket Packet

Name \_\_\_\_\_

Date \_\_\_\_\_

Use the RDW process to solve the problem below. Use a letter to represent the unknown.

Sandra keeps her sticker collection in 7 albums. Each album has 40 stickers in it. She starts a new album that has 9 stickers in it. How many total stickers does she have in her collection?

Name \_\_\_\_\_

Date \_\_\_\_\_

Use the RDW process to solve the problem below. Use a letter to represent the unknown.

Jaden's bottle contains 750 milliliters of water. He drinks 520 milliliters at practice and then another 190 milliliters on his way home. How many milliliters of water are left in Jaden's bottle when he gets home?

Name \_\_\_\_\_

Date \_\_\_\_\_

Use the RDW process to solve the problem below. Use a letter to represent the unknown.

Twenty packs of fruit snacks come in a box. Each pack weighs 6 ounces. Students eat some. There are 48 ounces of fruit snacks left in the box. How many ounces of fruit snacks did the students eat?

Name \_\_\_\_\_

Date \_\_\_\_\_

List as many attributes as you can to describe each polygon below.

1.

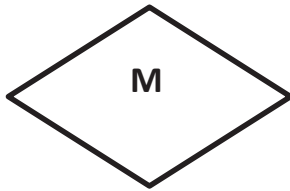

2.



Name \_\_\_\_\_

Date \_\_\_\_\_

Jonah draws the polygon below. Use your ruler and right angle tool to measure his polygon. Then, answer the questions below.



1. Is Jonah's polygon a regular polygon? Explain how you know.
2. How many right angles does his polygon have? Circle the right angles on his polygon.
3. How many sets of parallel lines does his polygon have?
4. What is the name of Jonah's polygon?



Name \_\_\_\_\_

Date \_\_\_\_\_

Use a ruler and a right angle tool to help you draw a shape that matches the attributes of Jeanette's shape. Label your drawing to explain your thinking.

Jeanette says her shape has 4 right angles and 2 sets of parallel sides. It is not a regular quadrilateral.

Name \_\_\_\_\_

Date \_\_\_\_\_

Use your tetrominoes to make a rectangle that has an area of 20 square units. Then, color the grid to show how you made your rectangle. You may use the same tetromino more than once.

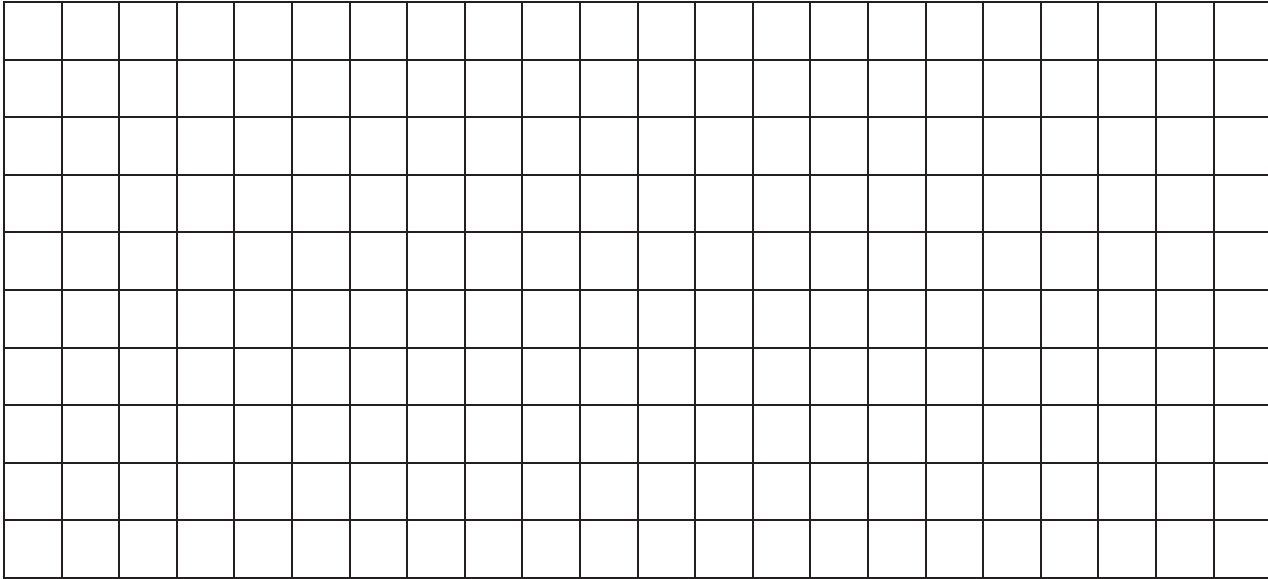

Name \_\_\_\_\_

Date \_\_\_\_\_

Choose three shapes from your tangram puzzle. Trace them below. Label the name of each shape, and describe *at least* one attribute that they have in common.

Name \_\_\_\_\_

Date \_\_\_\_\_

Nancy uses her tangram pieces to make a trapezoid without using the square piece. Below, sketch how she might have created her trapezoid.

Name \_\_\_\_\_

Date \_\_\_\_\_

Jason paints the outside edges of a rectangle purple. Celeste paints the inside of the rectangle yellow.

1. Use your crayons to color the rectangle that Jason and Celeste painted.



2. Which color represents the perimeter of the rectangle? How do you know?

Name \_\_\_\_\_

Date \_\_\_\_\_

Estimate to draw at least four copies of the given regular hexagon to make a new shape, without gaps or overlaps. Outline the perimeter of your new shape with a highlighter. Shade in the area with a colored pencil.

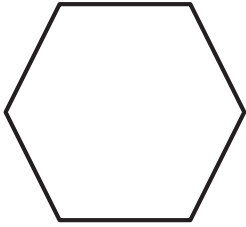

Name \_\_\_\_\_

Date \_\_\_\_\_

Measure and label the side lengths of the shape below in centimeters. Then, find the perimeter.

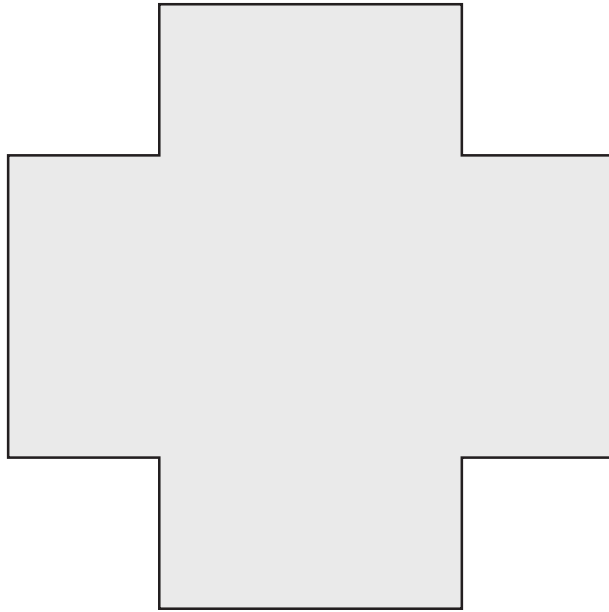

Perimeter = \_\_\_\_\_

= \_\_\_\_\_ cm

Name \_\_\_\_\_

Date \_\_\_\_\_

Which shape below has the greater perimeter? Explain your answer.

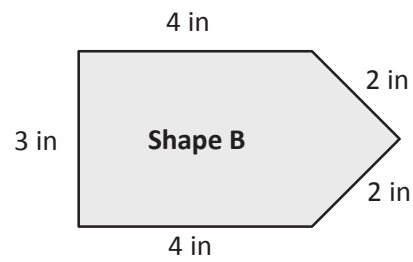
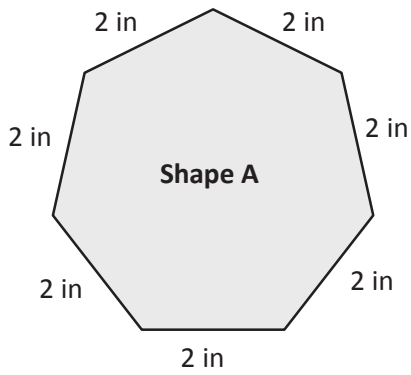



Name \_\_\_\_\_

Date \_\_\_\_\_

Travis traces a regular pentagon on his paper. Each side measures 7 centimeters. He also traces a regular hexagon on his paper. Each side of the hexagon measures 5 centimeters. Which shape has a greater perimeter? Show your work.

Name \_\_\_\_\_

Date \_\_\_\_\_

Marlene ropes off a square section of her yard where she plants grass. One side length of the square measures 9 yards. What is the total length of rope Marlene uses?

Name \_\_\_\_\_

Date \_\_\_\_\_

Use your string to find the perimeter of the shape below to the nearest quarter inch.

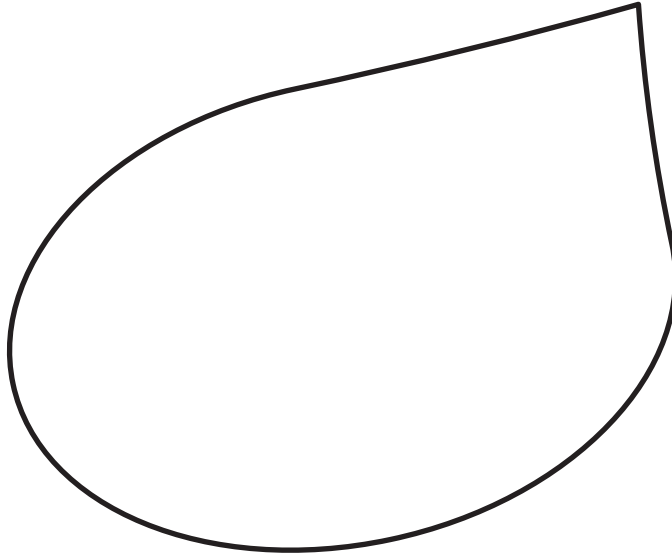

Name \_\_\_\_\_

Date \_\_\_\_\_

Label the unknown side lengths. Then, find the perimeter of the shaded rectangle.

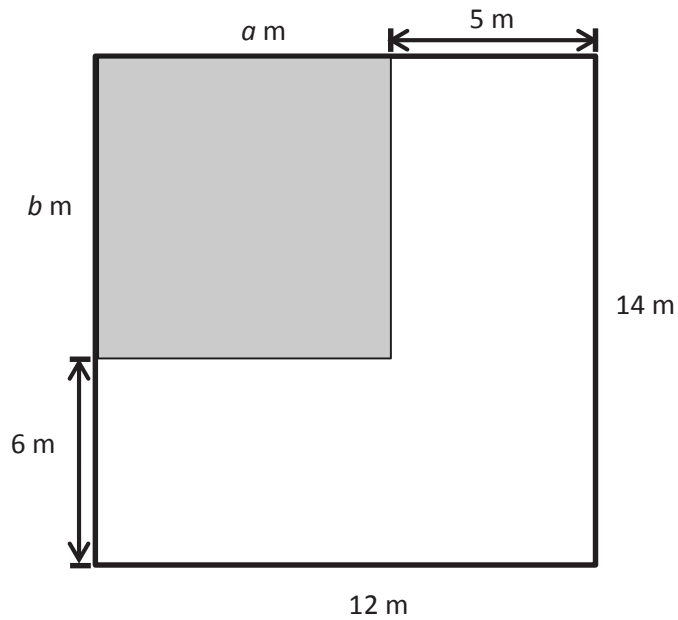

Name \_\_\_\_\_

Date \_\_\_\_\_

Tessa uses square-centimeter tiles to build rectangles with an area of 12 square centimeters. She draws the rectangles as shown below. Label the unknown side lengths of each rectangle. Then, find the perimeter of each rectangle.

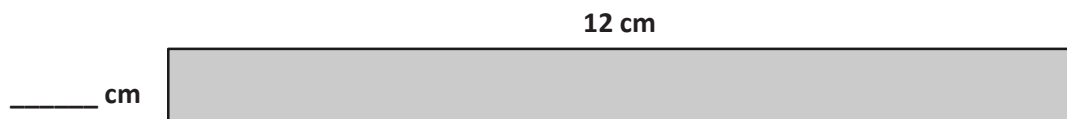

P = \_\_\_\_\_

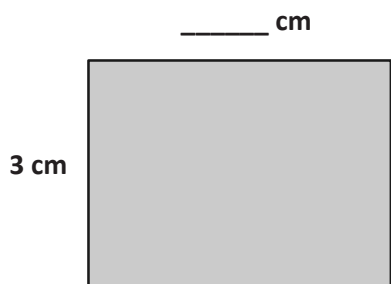

P = \_\_\_\_\_



P = \_\_\_\_\_

Name \_\_\_\_\_

Date \_\_\_\_\_

Use unit square tiles to make rectangles for the given number of unit squares. Complete the chart to show how many rectangles you made for the given number of unit squares. You might not use all the spaces in the chart.

Number of unit squares = <b>20</b>	
Number of rectangles I made: _____	
Width	Length

Name \_\_\_\_\_

Date \_\_\_\_\_

Use your square unit tiles to build as many rectangles as you can with a perimeter of 8 units.

- a. Estimate to draw your rectangles below. Label the side lengths of each rectangle.

- b. Find the areas of the rectangles in part (a) above.

Name \_\_\_\_\_

Date \_\_\_\_\_

On the grid below, shade and label at least two different rectangles with a perimeter of 20 centimeters.

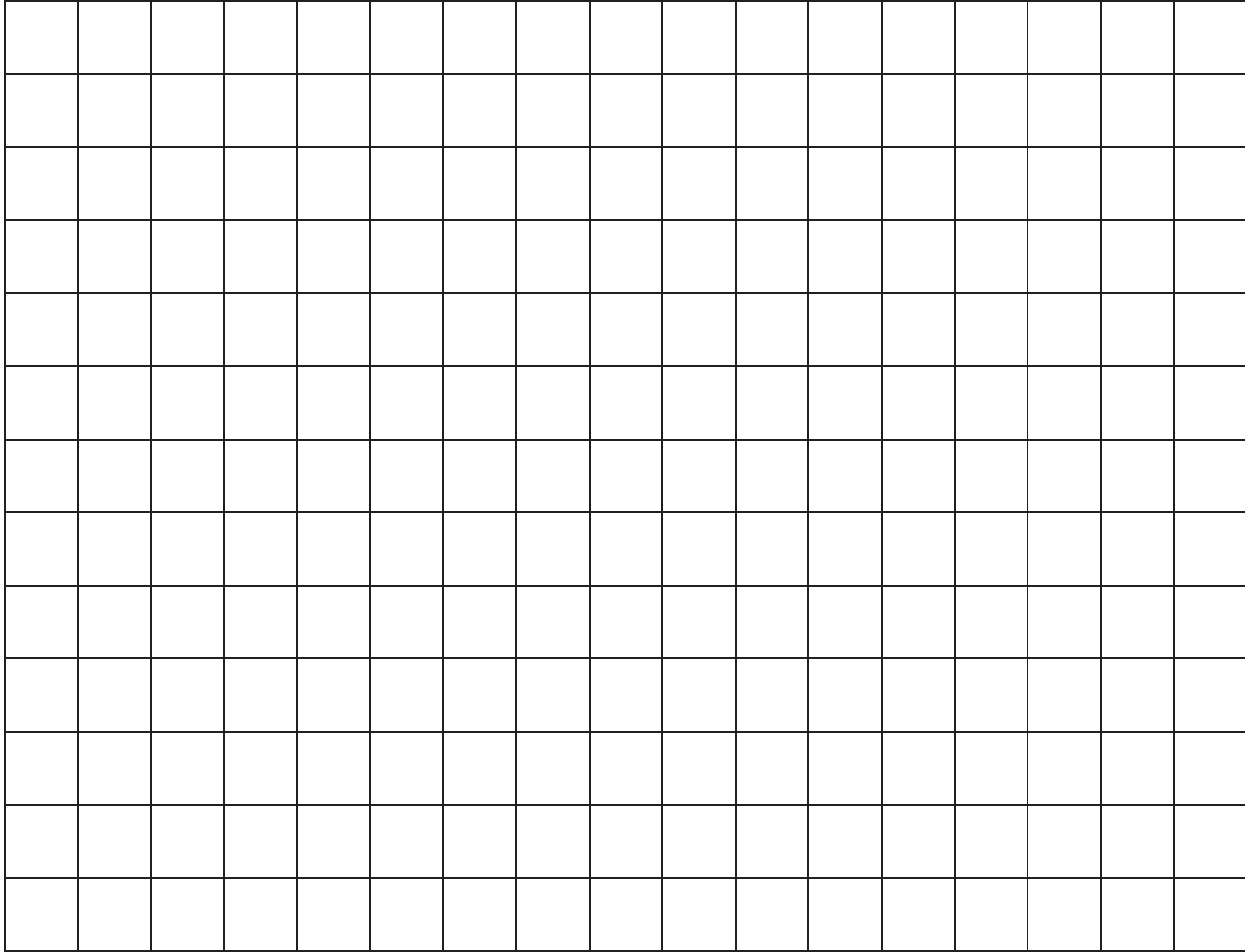



Name \_\_\_\_\_

Date \_\_\_\_\_

Suppose you have a rectangle with a perimeter of 2 cm. What can you conclude about the side lengths? Can all 4 sides of the rectangle measure a whole number of centimeters?

Name \_\_\_\_\_

Date \_\_\_\_\_

Adriana traces a regular triangle to create the shape below. The perimeter of her shape is 72 centimeters. What are the side lengths of the triangle?

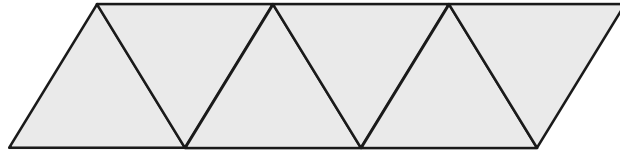

Name \_\_\_\_\_

Date \_\_\_\_\_

Estimate to draw three different rectangles with a perimeter of 16 centimeters. Label the width and length of each rectangle.

Name \_\_\_\_\_ Date \_\_\_\_\_

1. Sketch rectangles with the following perimeters. Label the side lengths.

a. 22 cm

b. 30 cm

2. Explain the steps you took to create the rectangles with the given perimeters.



Name \_\_\_\_\_

Date \_\_\_\_\_

1. Record the perimeters and areas of Rectangles A and B in the chart below.

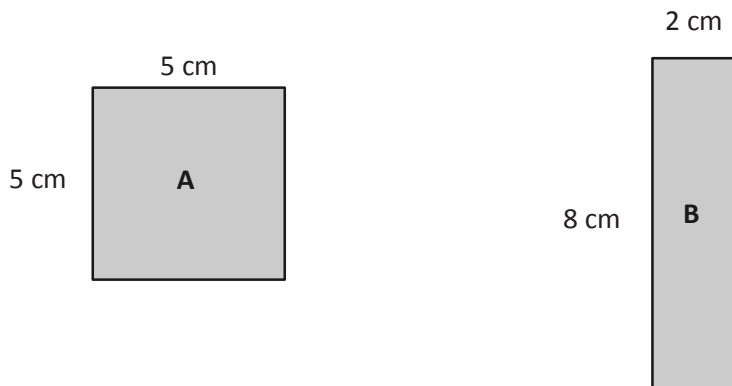

Rectangle:	Width and Length:	Perimeter	Area
A	_____ cm by _____ cm		
B	_____ cm by _____ cm		

2. What is the same about Rectables A and B? What is different?

Name \_\_\_\_\_

Date \_\_\_\_\_

Jennifer measures her rectangular sandbox and finds the width is 8 feet and the length is 6 feet.

a. Estimate to draw Jennifer's sandbox, and label the side lengths.

b. What is the area of Jennifer's sandbox?

c. What is the perimeter of Jennifer's sandbox?

Name \_\_\_\_\_

Date \_\_\_\_\_

Jeannette draws four identical squares as shown below to make a new, larger square. The length of one of the small square sides is 8 centimeters. What is the perimeter of the new, larger square?

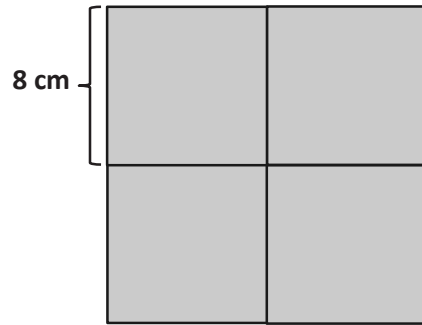



Name \_\_\_\_\_

Date \_\_\_\_\_

Jayden solves the problem as shown below.

The recreation center soccer field measures 35 yards by 65 yards. Chris dribbles the soccer ball around the field 4 times. What is the total number of yards Chris dribbles the ball?

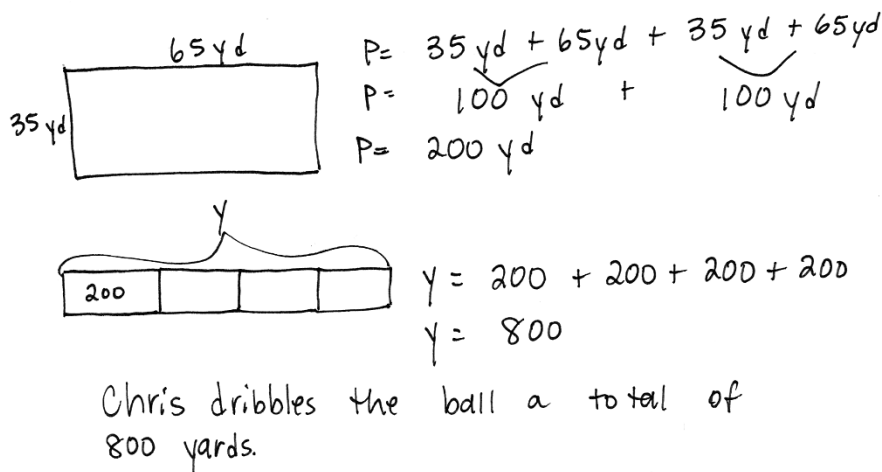

$P = 35 \text{ yd} + 65 \text{ yd} + 35 \text{ yd} + 65 \text{ yd}$   
 $P = 100 \text{ yd} + 100 \text{ yd}$   
 $P = 200 \text{ yd}$

$y = 200 + 200 + 200 + 200$   
 $y = 800$

Chris dribbles the ball a total of 800 yards.

1. What strategies did Jayden use to solve this problem?

2. What did Jayden do well?

Name \_\_\_\_\_

Date \_\_\_\_\_

Marty shades the square as shown below and says one-half of the big square is shaded. Do you agree? Why or why not?

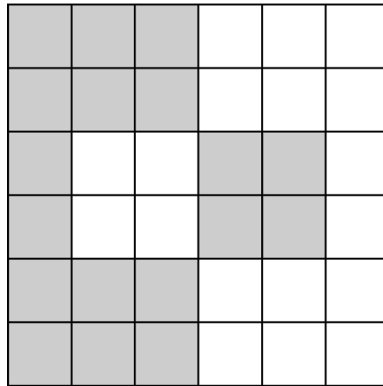

Name \_\_\_\_\_

Date \_\_\_\_\_

Riddian shades a circle as shown below.

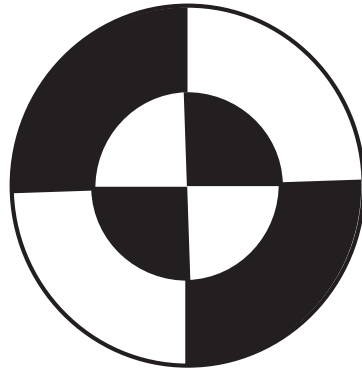

1. Is Riddian's shape about one-half shaded? How do you know?

2. Estimate to shade about one-half of the circle in an unusual way.

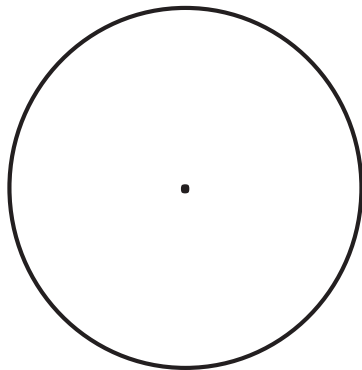

Name \_\_\_\_\_

Date \_\_\_\_\_

What fluency activity helped you the most in becoming fluent with your multiplication and division facts this year? Write three or four sentences to explain what made it so useful.

# Assessment Packet

Name \_\_\_\_\_

Date \_\_\_\_\_

1. Three shapes are shown below.
  - a. Circle the shape(s) with only one pair of parallel sides.
  - b. Cross out the shape(s) with two pairs of parallel sides.

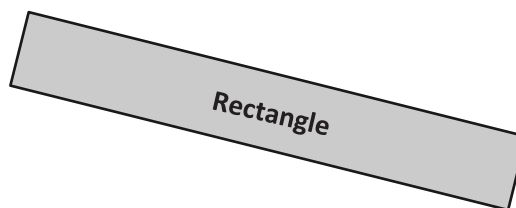
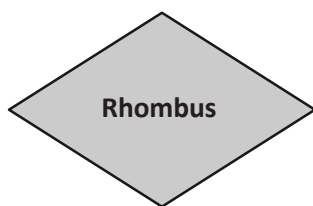

- c. Which of the three shapes are quadrilaterals? Explain how you know.



3. Mr. Cooper builds a fence to make a rectangular horse stall. The stall is 5 meters long and 7 meters wide. How many meters of fence does Mr. Cooper use? Draw a picture and write an equation to show your thinking.

4. Jamal wants to put wood trim around his rectangular bedroom and square closet. His bedroom is 10 feet wide and 8 feet long. His closet is 3 feet wide and 3 feet long.

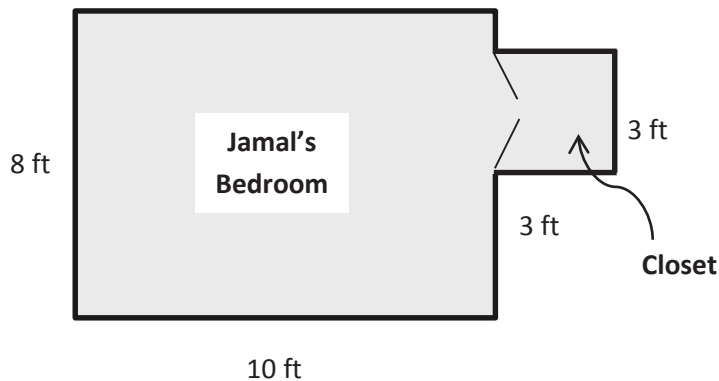

- a. Wood trim is sold by the foot. How many feet of wood trim does Jamal need to go around his bedroom and closet? Show your work.
- b. How much more wood trim does Jamal need for his bedroom than his closet? Write and solve an equation. Use a letter to represent the unknown.



5. The figure below is composed of rectangles. Use the picture and the descriptions to find the perimeter of the shape. Show your work.

- Each side labeled with **A** is 6 inches.
- Each side labeled with **B** is 3 inches.
- Each side labeled with **C** is 8 inches.

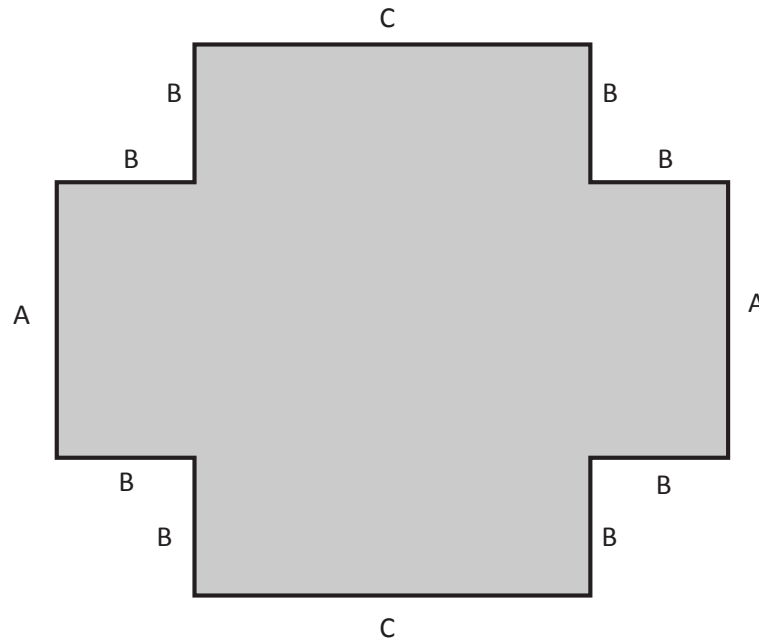

6. Mrs. Gomez builds a fence around her backyard. Her plan shows the fence as a dotted line below.

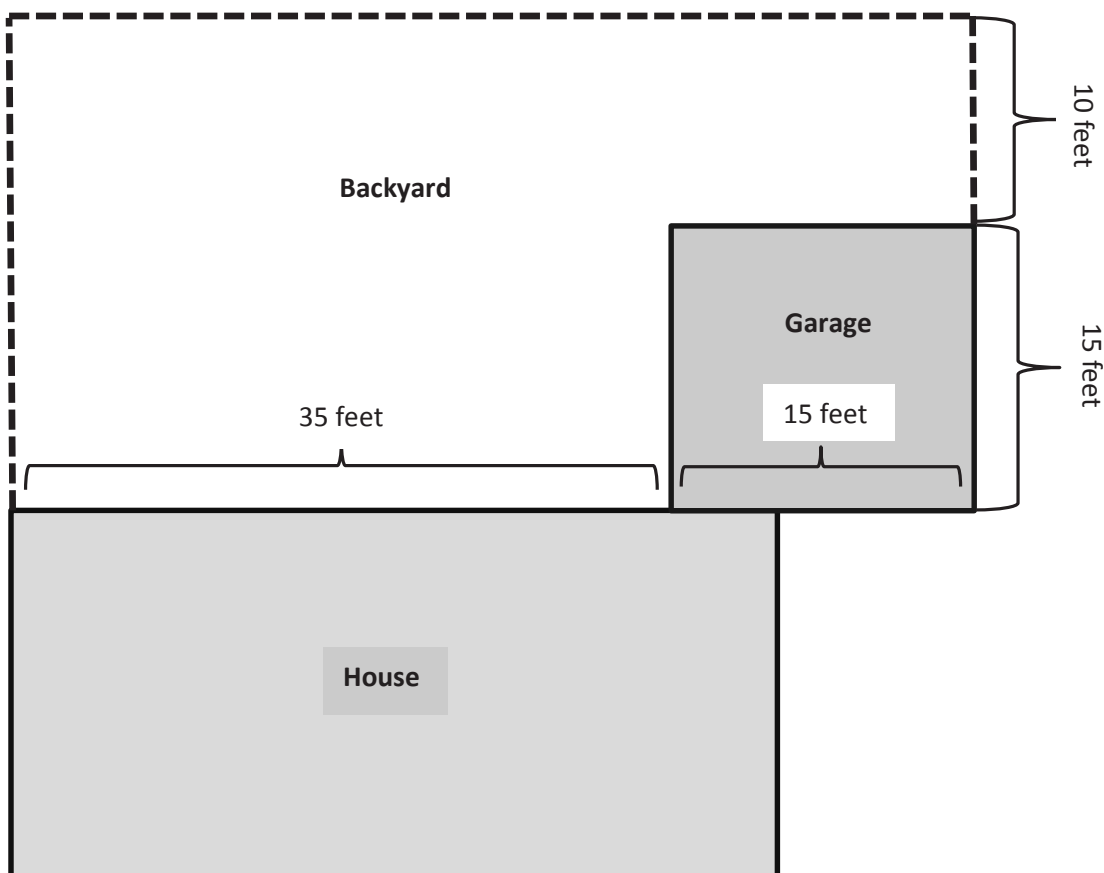

Together, the garage and backyard make a rectangle. The fence goes only where there is a dotted line. How many feet of fence does Mrs. Gomez need to build? Show your work.



2. Each shape has a missing side length labeled with a letter. The perimeter of the shape is labeled inside. Find the unknown side length for each shape.

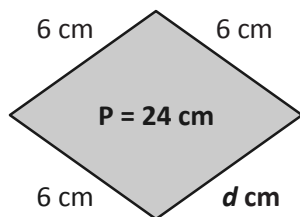
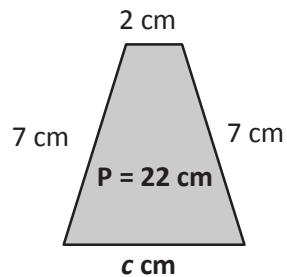
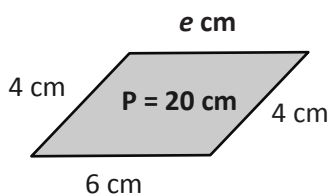
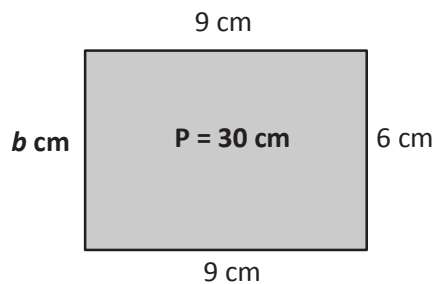
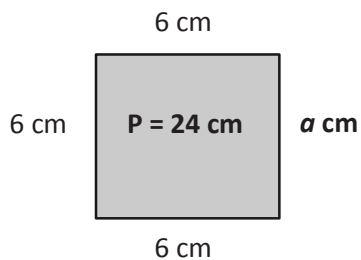

3. Suppose each  is 1 square centimeter.

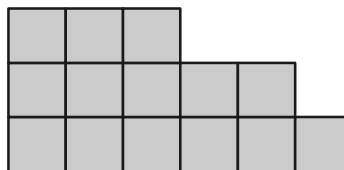
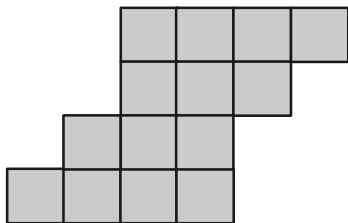

- a. Find the area and perimeter of each shape.
- b. John says, "If two shapes have the same area, they must also have the same perimeter." Is John correct? Use your answer from part (a) above to explain why or why not.

4. Mr. Jackson's class finds all possible perimeters for a rectangle composed of 36 centimeter tiles. The chart below shows how many students found each rectangle.

Perimeter	Number of Students
24 cm	6
26 cm	9
30 cm	5
40 cm	7
74 cm	4

- a. Check the students' work. Did they find all the possible perimeters? How do you know?

- b. Use the chart. Estimate to construct a line plot of how many students found each perimeter.

**Number of Students Who Found Each Perimeter**

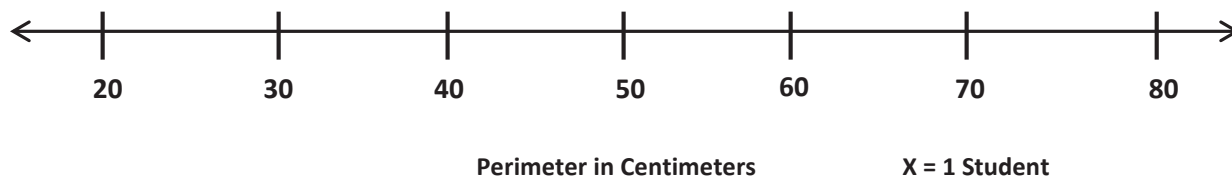

5. The square to the right has an area of 16 square centimeters.
- a. What is the length of each side? Explain how you know.

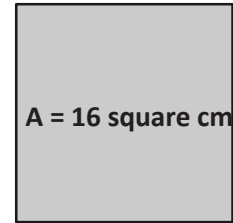

- b. Draw copies of the square above to make a figure with a perimeter of 32 centimeters.
- c. Write a number sentence to show that your figure has the correct perimeter of 32 centimeters.